

MCARWH Series Mechanical Artisan Heavy-Duty Architectural Wall Heater



Installation, Operation & Maintenance Instructions

Table 1. Specifications

MODEL	VOLTS	PHASE	WATTS	AMPS	MIN. SUPPLY WIRE GAUGE
MCARWH1802	120	1	1800 / 900	15.0 / 7.5	12
MCARWH4808	208	1	4000 / 2000	19.2 / 9.6	10
MCARWH4804	240	1	4800 / 2400	20.0 / 10.0	10
MCARWH4807	277	1	4800 / 2400	17.3 / 8.7	12

NOTE: The model numbers shown are Northern White color. Add suffix to the model number for the following colors:
AL = Aluminum, BZ = Bronze, W = Navajo White.

IMPORTANT INSTRUCTIONS

⚠ **WARNING** ⚠

WHEN USING ELECTRIC APPLIANCES, BASIC PRECAUTIONS SHOULD ALWAYS BE FOLLOWED TO REDUCE THE RISK OF FIRE, ELECTRIC SHOCK, AND INJURY TO PERSONS, INCLUDING THE FOLLOWING:

1. Read all instructions before installing or using this heater.
2. This heater is hot when in use. To avoid burns, do not let bare skin touch hot surfaces. Keep combustible materials, such as furniture, pillows, bedding, papers, clothes, etc. and curtains at least 3 feet (0.9 m) from the front of the heater.
3. Extreme caution is necessary when any heater is used by or near children or invalids and whenever the heater is left operating and unattended.
4. Do not operate any heater after it malfunctions. Disconnect power at service panel and have heater inspected by a reputable electrician before using.
5. Do not use outdoors.
6. To disconnect heater, turn controls to OFF, and turn OFF power to heater circuit at main disconnect panel.
7. Do not insert or allow foreign objects to enter any ventilation or exhaust opening as this may cause an electric shock, fire, or damage to the heater.
8. To prevent a possible fire, do not block air intake or exhaust in any manner.
9. A heater has hot and arcing or sparking parts inside. Do not use it in areas where gasoline, paint, or flammable liquids are used or stored.
10. Use this heater only as described in this manual. Any other use not recommended by the manufacturer may cause fire, electric shock, or injury to persons.
11. This heater is provided with a red alarm light that will illuminate only if the heater has turned off as a result of overheating. Should the sensor register an overheat condition, the heater will stop generating heat, the fan will turn off, and the red alarm light will turn ON. **DO NOT OPERATE THE HEATER WITH THE ALARM LIGHT ILLUMINATED.** See "TO RESET MANUAL RESET LIMIT" in OPERATING INSTRUCTION section.
12. This heater is intended for comfort heating applications and not intended for use in special environments. Do not use in damp or wet locations such as marine or greenhouse or in areas where corrosive or chemical agents are present.
13. When installing, see INSTALLATION INSTRUCTIONS for additional warnings and precautions.
14. For safe and efficient operation, and to extend the life of your heater, keep your heater clean - See MAINTENANCE INSTRUCTIONS.

SAVE THESE INSTRUCTIONS

INSTALLATION INSTRUCTIONS

⚠ WARNING ⚠

To prevent a possible fire, injury to persons or damage to the heater, adhere to the following:

1. Disconnect all power coming to heater at main service panel before wiring or servicing.
2. All wiring procedures and connections must be in accordance with the National and Local Codes having jurisdiction and the heater must be grounded.
3. Verify the power supply voltage coming to heater matches the ratings as shown on the heater nameplate.

CAUTION: ENERGIZING HEATER AT A VOLTAGE GREATER THAN THE VOLTAGE PRINTED ON THE NAMEPLATE WILL DAMAGE THE HEATER AND VOID THE WARRANTY AND COULD CAUSE A FIRE.

4. **CAUTION** - High temperature, risk of fire, keep electrical cords, drapery, furnishings, and other combustibles at least 3 feet (0.9 m) from front of heater. Do not install heater behind doors, below towel racks, or in an area where it is subject to being blocked by furniture, curtains or storage materials. Hot air from the heater may damage certain fabrics and plastics.
5. To reduce the risk of fire, do not store or use gasoline or other flammable vapors and liquids in the vicinity of the heater.
6. For wall mounting only with air discharge downward. Do NOT install in floor, ceiling, upside down (air discharge upward), or sideways.
7. The following minimum clearances must be maintained:
 - Bottom of heater to floor - 12" (305 mm).
 - Sides of heater to adjacent wall - 12" (305 mm).
 - Top of heater to ceiling - 36" (915 mm).
8. Do not operate the heater without the back box.
9. Do not use this heater for dry out purposes as the paint, plaster, sawdust and drywall sanding dust will permanently damage the heater and must be kept out of the heater.
10. Remove motor shipping bracket and yellow tag prior to operating this heater.

The heater is designed for recessed installation in 2" x 4" (50 mm x 101 mm) studs or larger wall sections using the back box provided. The heater may be wired with standard building wire (60°C). Refer to "Specifications" and heater nameplate for correct supply voltage and wire size.

NOTE: The optimum mounting height for this heater is 18" to 24" (450 mm to 600 mm) from floor to bottom of back box. DO NOT install closer than 12" (305 mm) from the floor.

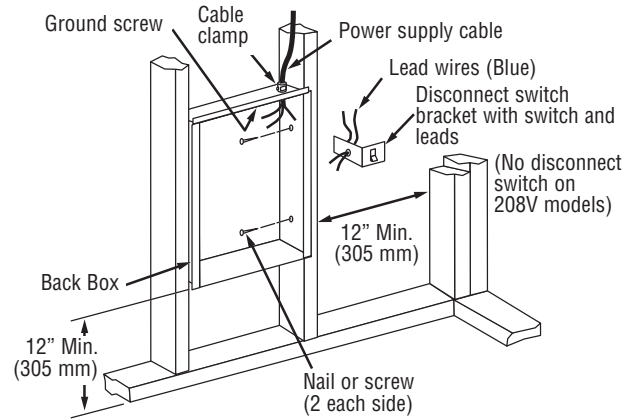

Figure 1: Locating Back Box in New Construction
Mounting Clearances

CAUTION ⚠

TO PROVIDE FOR SAFE OPERATION, THE FOLLOWING CLEARANCES MUST BE MAINTAINED.

Wall Mounting Only:

- a. Minimum twelve (12) inches (305 mm) to floor;
- b. Minimum twelve (12) inches (305 mm) to adjacent walls;
- c. Minimum thirty six (36) inches (915 mm) to ceiling.

⚠ WARNING ⚠

TO PREVENT HAZARD OF FIRE OR ELECTRICAL SHOCK, DO NOT INSTALL WITHOUT BACK BOX.

CAUTION ⚠

TO PREVENT POSSIBLE DAMAGE TO POWER WIRING, USE ONLY THE KNOCKOUTS PROVIDED IN BACK BOX.

Installation of Back Box in New Construction (See Figure 1).

NOTE: If the finished wall surface is already up, follow instructions for "Installation of Back Box in Existing Construction."

1. Place the back box between two 16" (406 mm) center-to-center wall studs at the desired mounting height but no closer than 12" (305 mm) to adjacent wall or floor.

NOTE: If wall studs are spaced greater than 16" (407 mm) on center, additional framing supports may be necessary.

2. Align back box such that the bottom and sides will be flush with finished wall surface (top flange of back box should protrude approximately 1/2" (12.7 mm) from finished wall surface (You must know the thickness of the finished wall when installing).
3. Secure the back box in position with wood screws or nails as shown in Figure 1.
4. Run a power supply cable into the knockout area in the upper right hand corner of the back box (see Figure 1). All wiring must be in accordance with National and Local Electrical Codes. Refer to Specifications for correct wire size.
5. Remove disconnect switch bracket by loosening two screws on the right side.
6. Install a cable clamp in the knockout in the top of the back box.

- Insert power supply cable through cable clamp, allowing at least 6" (152 mm) of leads to extend inside the back box. Connect the blue lead wires of disconnect switch to the supply wire leads using wire connectors (see Figure 3, Wiring Diagram).

NOTE: If power supply is provided by standard non-metallic sheathed cable (Romex) and the supply voltage is 240 or 208 volts (two power wires), the white wire color must be changed using black electrical tape to comply with the NEC. White is only allowed for a Neutral conductor.

- Connect building ground conductor to the back box using the green pigtail lead located in the inside top of the back box and secure second green pigtail lead to back box green pigtail.
- Feed remaining 2 wires from disconnect switch through hole in switch bracket and secure disconnect switch bracket in place by tightening screws.
- Secure disconnect switch bracket in place by tightening screws.

⚠ WARNING ⚠

POWER SUPPLY VOLTAGE MUST BE THE SAME AS HEATER VOLTAGE RATING SHOWN ON HEATER NAMEPLATE. CONNECTING TO A VOLTAGE IN EXCESS OF NAMEPLATE RATING WILL DAMAGE HEATER AND VOID WARRANTY. ALL CONNECTIONS MUST BE MADE WITH APPROPRIATELY SIZED LISTED WIRE CONNECTORS.

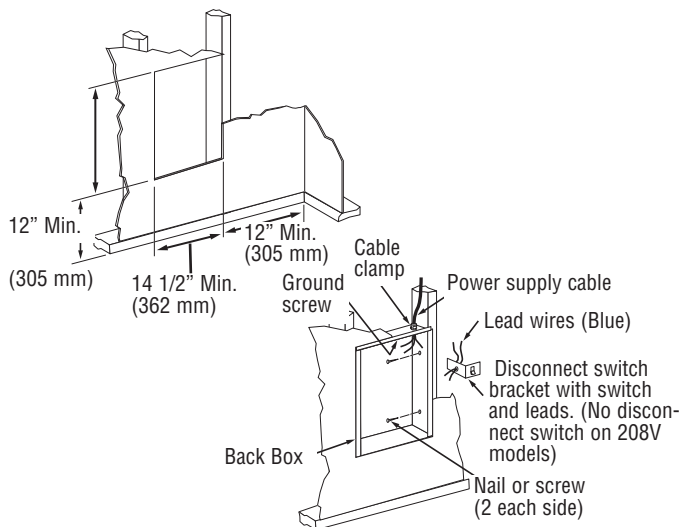

Figure 2: Locating Back Box in Existing Construction

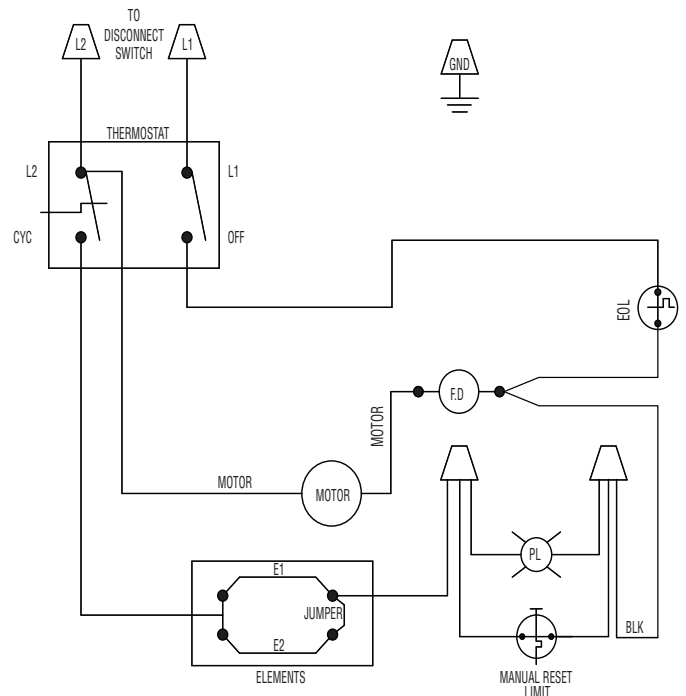

Figure 3: Wiring Diagram

Installation of Recessed Back Box in Existing Construction

- Provide a wall opening 14-3/4" (375 mm) wide by 18-1/2" (470 mm) high at the desired mounting height, but no closer than 12" (305 mm) from floor. (See Figure 2.) Locate so that at least one side of opening is at wall stud.
- Run a power supply cable into the knockout area in the upper right hand corner of the wall opening (see Figure 2). All wiring must be in accordance with National and Local Electrical Codes. Refer to Specifications for correct wire size.
- Remove disconnect switch bracket by loosening two screws on the right side.
- Install a cable clamp in the knockout in the top of the back box.
- Insert power supply cable through cable clamp, allowing at least 6" (152 mm) of leads to extend inside the back box. Connect the blue lead wires of disconnect switch to the supply wire leads using wire connectors (see Figure 4, Wiring Diagram).

NOTE: If power supply is provided by standard non-metallic sheathed cable (Romex) and the supply voltage is 240 or 208 volts (two power wires), the white wire color must be changed using black electrical tape to comply with the NEC. White is only allowed for a Neutral conductor.

- Connect building ground conductor to the back box using the green screw located in the inside top of the back box.
- Feed remaining 2 wires from disconnect switch through hole in switch bracket and secure disconnect switch bracket in place by tightening screws.
- Insert back box in wall opening being careful not to damage the supply wiring. Secure the back box in place with wood screws or nails.

Building Management Systems (BMS)

To utilize BMS capabilities of this unit, there are two (optional) accessories available. Model WHR2A which has a 24 volt holding coil can switch the heaters ON/OFF from remote source. Model WHR12A which has a 120 volt holding coil can switch the heaters ON/OFF from remote source.

Refer to the control installation manual when installing.

Installation of Back Box with Optional Surface-Mounting Frame HTWHSM (See Figure 4)

1. Secure back box to wall with knockouts in upper right hand corner using screws and anchors.
2. Hang the surface-mounting frame on the back box. Ensure that the back edge of the surface-mounting frame is flush against the wall.

NOTE: If heater is located in a high traffic area, where it may be subjected to vandalism or abuse, take extreme care to see that the back box is firmly attached to the wall.

3. Power Supply Wiring

NOTE: Wiring Compartment Volume - 119in³ (1950cm³).

- a. Run a power supply cable into the area to the right of the mounting frame. Arrangement of wiring to this point must be in accordance with National and Local codes. Refer to Table 1 on page 1 for proper wire size.

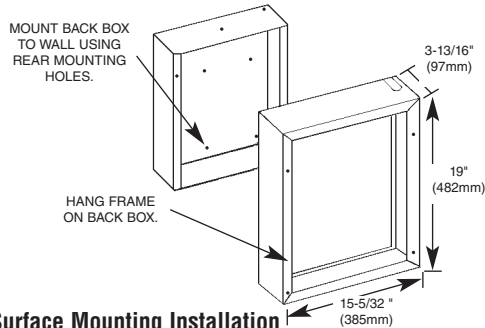

Figure 4- Surface Mounting Installation

NOTE: If the wiring is to run through the wall, cut a hole in the area of the top right corner of the back box. Run the supply wire through this hole. Then remove the “knockout” from the top of the box and proceed to step C.

- c. Remove disconnect switch bracket by loosening the two screws on the right side.
- d. Feed the power supply cable through the frame allowing 6in (152mm) of lead to remain inside the back box (using a cable clamp, connector, or other suitable strain relief)
- e. Secure the power supply cable to the back box (using cable clamp, connector, or other suitable strain relief) allowing 6in (152mm) of lead to remain inside the back box.
- f. Connect supply wires to blue wires of disconnect switch using wiring connectors (see wiring diagram 3, Page 3).
- g. Ground the back box by connecting the supply ground lead wire to the green ground screw located in the inside top of the back box.
- h. Feed remaining 2 wires from disconnect switch through hole in the switch bracket and secure disconnect switch bracket in place.

Installation of Heater / Grille into Back Box

Note to Installer: Converting heater to half wattage (Not applicable to MCARWH1802 120 Volt Models)

The MCARWH Series wall heaters are manufactured and shipped at the higher rated wattage. Full wattage heaters can be converted to half wattage by doing the following steps.

1. Remove the red jumper wire as shown in Figure 5 and discard.
2. To permanently make the heater half wattage, cut the male terminal spade, carefully not to damage the cold pin and discard.
3. Mark the wattage of the heater on the white label inside the back box.

After back box is completely installed and no further construction dirt is expected, clean debris from back box and remove heater assembly from its carton.

1. Lift and rotate the grille assembly into the back box carefully to ensure the wiring is not trapped between the grille assembly and back box. Position the grille assembly in front of the back box and insert Control Shelf into the notches on either side of the back box. At the same time hooking the tabs on the bottom corners of the grille assembly over the bottom flange of the back box. Refer to figures 6 and 7.
2. With the top of the grille assembly leaning forward, supported by the first notch in control shelf, extend the lead wires from the back of the top of the heater grille assembly to the (2) power wires of the disconnect switch assembly and connect according to Wiring Diagram shown in Figure 3 (page 3)
3. If a surface mounting frame is used, ensure that the frame is even with all four sides of the heater.
4. Connect the two disconnected switch wires to the heater wires using wire nuts (provided). After the connection, carefully push wires back into the opening.
5. Turn thermostat to the extreme counterclockwise position in OFF position.
6. Push disconnect switch to ON position.
7. Tighten top cover screws down to hold grille in place. See Figure 8.

CAUTION

THE HEATER ASSEMBLY MUST BE CAREFULLY POSITIONED TO ENSURE THE CONTROL WIRES ARE NOT TRAPPED BETWEEN THE HEATER ASSEMBLY AND THE BACK BOX.

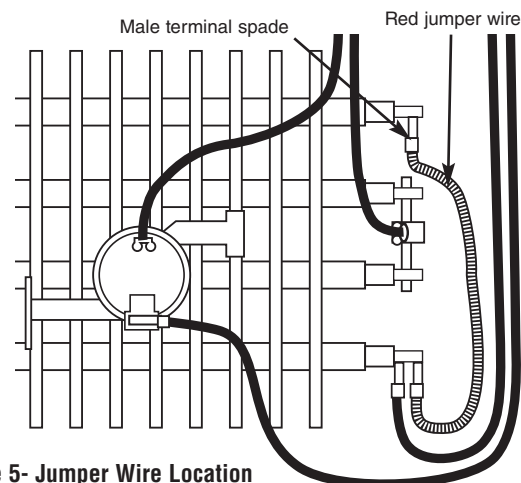

Figure 5- Jumper Wire Location

OPERATION INSTRUCTIONS

1. Heater must be properly installed before operation.
2. Turn power supply ON at the service panel for this heater.
3. Rotate the thermostat fully clockwise. This should energize the heating elements and cause warm air to flow from the hot air discharge at the openings in the bottom front part of the grille. This may take a minute or two for the fan delay to operate the fan.
4. After the operation check, rotate the thermostat counterclockwise to the desired position to obtain room comfort.

Note: For best results, the heater should be left "ON" constantly during the heating season because the thermostat, when properly set, will maintain the desired temperature.

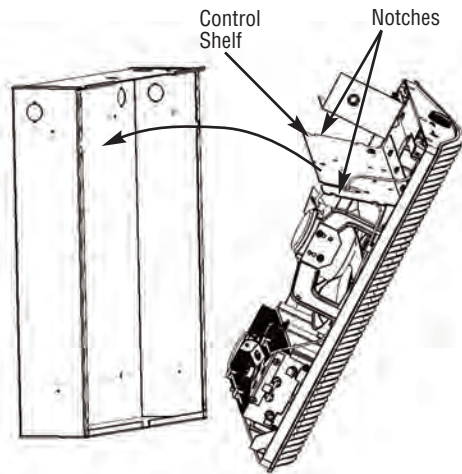

Figure 6- Installation of Heater/Grille Assembly

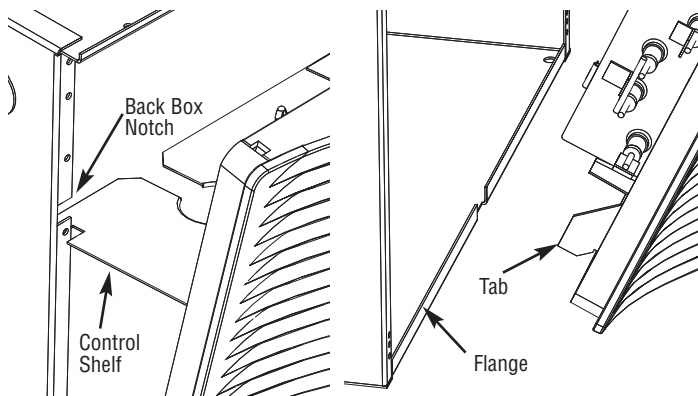

Figure 7- Heater / Grille Assembly Detail, Grille Supported for Wiring

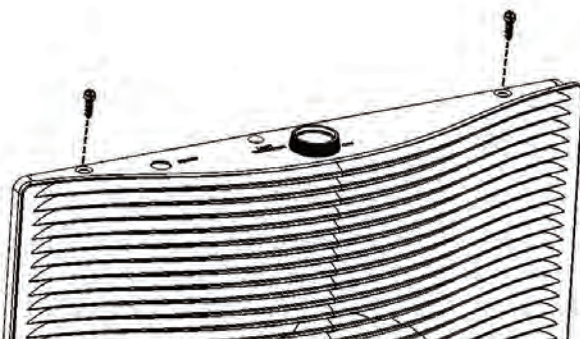

Figure 8- Securing Bezel

CAUTION

THE ACTIVATION OF THE THERMAL LIMIT CONTROL AND RED WARNING LIGHT OCCURS IF THE HEATER OVERHEATS. CHECK HEATER TO MAKE SURE IT IS NOT BLOCKED – IF SO, REMOVE THE BLOCKAGE. IF THERE IS NO BLOCKAGE, IT IS RECOMMENDED THAT THE HEATER BE INSPECTED BY A REPUTABLE ELECTRICIAN OR REPAIR SERVICE TO ENSURE THE HEATER IS NOT DAMAGED. DO NOT CONTINUE TO USE HEATER IF IT REPEATEDLY CYCLES OFF ON THIS THERMAL LIMIT.

TO RESET THERMAL LIMIT CONTROL

Your heater is equipped with a manual reset safety thermal limit control that will automatically turn the heater OFF to prevent a fire if the heater overheats. This control is mounted inside the heater (top left). On the top cover of the grille assembly it is marked "Reset Button." REMOVE the plug button that covers the hole. To reset, allow the heater to cool, then push the red button that is visible through the hole downward (you may have to use a pencil- blunt side) to reach the button. The heater should immediately return to normal operation.

WARNING

DO NOT TAMPER WITH OR BYPASS ANY THERMAL LIMITS INSIDE HEATER.

NOTE: The unit is provided with an End of Life "oneshot" protective device. This serves as a back up protector in extreme conditions if the overheat protector fails to maintain safe temperatures during an overheat condition. If the end of life control activates, the heater must be checked by a reputable repairman.

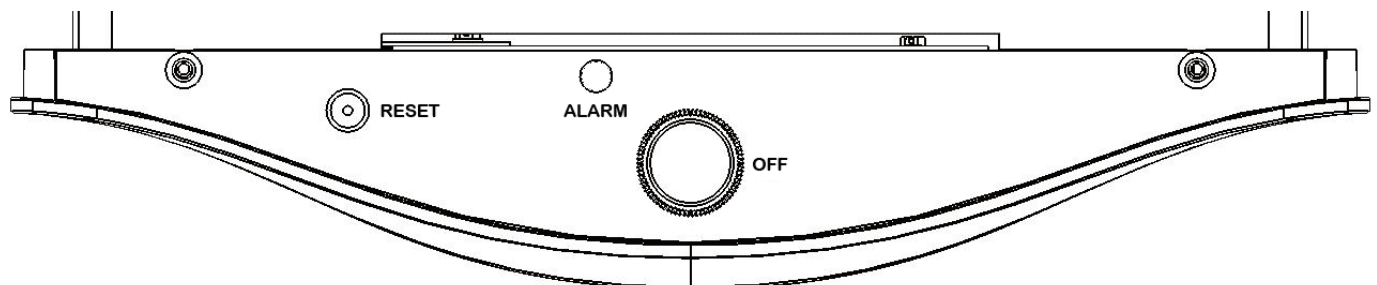

Figure 9- Top Panel Layout

MAINTENANCE INSTRUCTIONS

It is important to keep this heater clean. Your heater will give you years of service and comfort with only minimum care. To assure efficient operation follow the simple instructions below.

WARNING

ALL SERVICING BEYOND SIMPLE CLEANING THAT REQUIRES DISASSEMBLY SHOULD BE PERFORMED BY QUALIFIED SERVICE PERSONNEL.

WARNING

TO REDUCE RISK OF FIRE AND ELECTRIC SHOCK OR INJURY, DISCONNECT ALL POWER COMING TO HEATER AT MAIN SERVICE PANEL AND CHECK THAT THE ELEMENT IS COOL BEFORE SERVICING OR PERFORMING MAINTENANCE.

User Cleaning Instructions:

1. After the heater has cooled, a vacuum cleaner with brush attachment may be used to remove dust and lint from exterior surfaces of the heater including the grille openings.
2. With a damp cloth, wipe dust and lint from grille and exterior surfaces.
3. Return power to heater and check to make sure it is operating properly.

Maintenance Cleaning Instructions:

(To be performed only by Qualified Service Personnel)

At least annually, the heater should be cleaned and serviced by a qualified service person to assure safe and efficient operation. This should include the removal of the heater grille assembly from the back box to clean residue from the unit. After completing the cleaning and servicing, the heater should be fully reassembled and checked for proper operation.

REPAIR PARTS

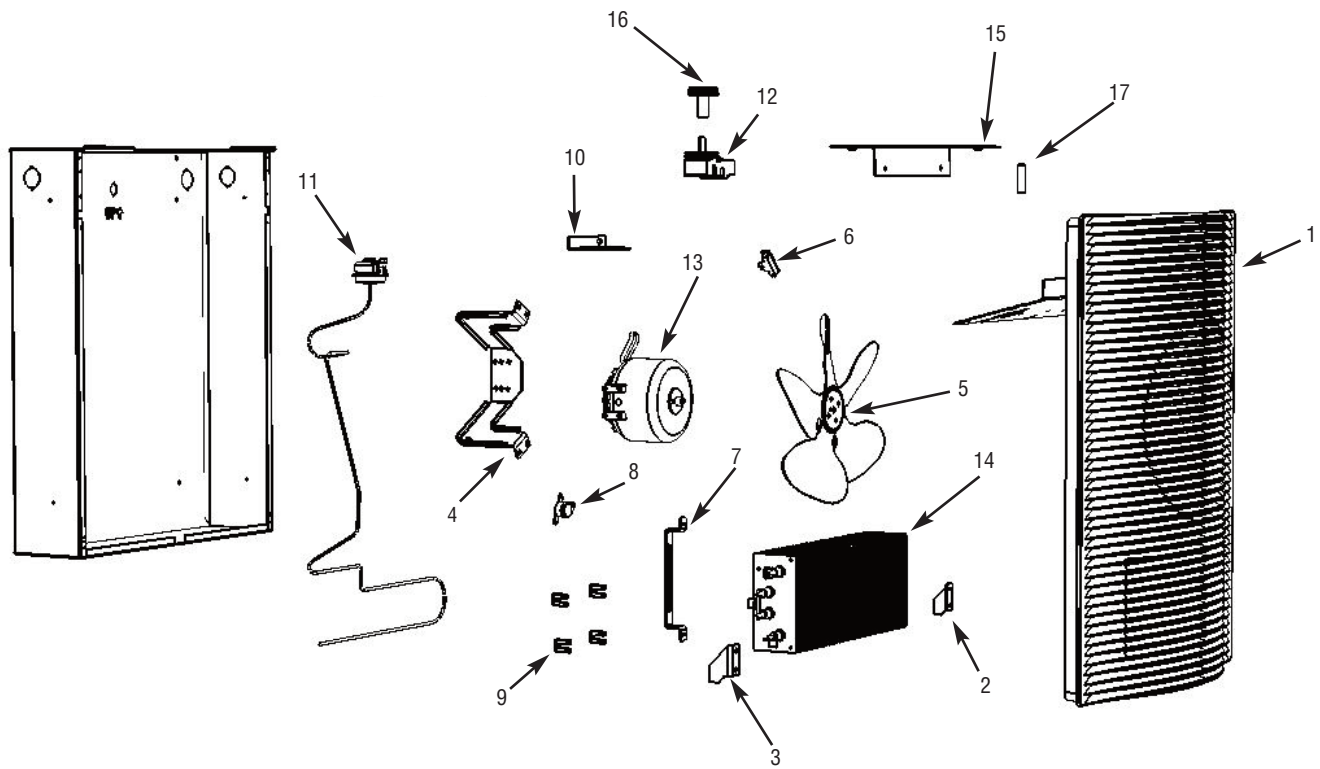

Repair Parts List

Ref No	Description	Part Number	MCARWH4804	MCARWH4808	MCARWH4807	MCARWH1802
1	Grille	2501-11023-VAR*	2501-11023-VAR*	2501-11023-VAR*	2501-11023-VAR*	2501-11023-VAR*
2	Cover Bracket Lower Left	1215-11070-000	1215-11070-000	1215-11070-000	1215-11070-000	1215-11070-000
3	Cover Bracket Lower Left	1215-11070-001	1215-11070-001	1215-11070-001	1215-11070-001	1215-11070-001
4	Motor Mount Bracket	1215-2235-002	1215-2235-002	1215-2235-002	1215-2235-002	1215-2235-002
5	Fan Blade	490030103	490030103	490030103	490030103	490030103
6	Thermal Cutout	4520-2030-000	4520-2030-000	4520-2030-000	4520-2030-000	4520-2030-000
7	Element Retention Bracket	1215-11090-000	1215-11090-000	1215-11090-000	1215-11090-000	1215-11090-000
8	Fan Delay	410074000	410074000	410074000	410074000	1414-2039-000
9	Clip-limit Capillary	402040001	402040001	402040001	402040001	402040001
10	Bracket - Limit	1215-11101-000	1215-11101-000	1215-11101-000	1215-11101-000	1215-11101-000
11	Protect or Manual Reset	4520-11019-000	4520-11019-000	4520-11019-000	4520-11019-000	4520-11019-000
12	Thermostat 2-Pole	5813-2027-000	5813-2027-000	5813-2027-000	5813-2027-000	5813-2027-000
13	Motor	3900-2010-000	3900-2010-000	3900-2010-001	3900-2010-001	3900-2010-003
14	Element	302012810	302012807	302012811	302012811	302012828
15	Bezel	4503-11015-000	4503-11015-000	4503-11015-000	4503-11015-000	4503-11015-000
16	Control Knob	3301-11013-000	3301-11013-000	3301-11013-000	3301-11013-000	3301-11013-000
17	Light (Alarm)	3510-2010-000	3510-2010-000	3510-2010-000	3510-2010-000	3510-2010-000

***NOTE:** The standard color is Northern White. Add suffix to the model number for the following colors:
 AL = Aluminum, BZ = Bronze, W = Navajo White. Call Factory for part number.

LIMITED WARRANTY

All products manufactured by Marley Engineered Products are warranted against defects in workmanship and materials for one year from date of installation, except heating elements which are warranted against defects in workmanship and materials for five years from date of installation. This warranty does not apply to damage from accident, misuse, or alteration; nor where the connected voltage is more than 5% above the nameplate voltage; nor to equipment improperly installed or wired or maintained in violation of the product's installation instructions. All claims for warranty work must be accompanied by proof of the date of installation.

The customer shall be responsible for all costs incurred in the removal or reinstallation of products, including labor costs, and shipping costs incurred to return products to Marley Engineered Products Service Center. Within the limitations of this warranty, inoperative units should be returned to the nearest Marley authorized service center or the Marley Engineered Products Service Center, and we will repair or replace, at our option, at no charge to you with return freight paid by Marley. It is agreed that such repair or replacement is the exclusive remedy available from Marley Engineered Products.

THE ABOVE WARRANTIES ARE IN LIEU OF ALL OTHER WARRANTIES EXPRESSED OR IMPLIED, AND ALL IMPLIED WARRANTIES OF MERCHANTABILITY AND FITNESS FOR A PARTICULAR PURPOSE WHICH EXCEED THE AFORESAID EXPRESSED WARRANTIES ARE HEREBY DISCLAIMED AND EXCLUDED FROM THIS AGREEMENT. MARLEY ENGINEERED PRODUCTS SHALL NOT BE LIABLE FOR CONSEQUENTIAL DAMAGES ARISING WITH RESPECT TO THE PRODUCT, WHETHER BASED UPON NEGLIGENCE, TORT, STRICT LIABILITY, OR CONTRACT.

Some states do not allow the exclusion or limitation of incidental or consequential damages, so the above exclusion or limitation may not apply to you. This warranty gives you specific legal rights, and you may also have other rights which vary from state to state.

For the address of your nearest authorized service center, contact Marley Engineered Products in Bennettsville, SC, at 1-800-642-4328. Merchandise returned to the factory must be accompanied by a return authorization and service identification tag, both available from Marley Engineered Products. When requesting return authorization, include all catalog numbers shown on the products.

HOW TO OBTAIN WARRANTY SERVICE AND WARRANTY PARTS PLUS GENERAL INFORMATION

- | | |
|--------------------------------|---|
| 1. Warranty Service or Parts | 1-800-642-4328 |
| 2. Purchase Replacement Parts | 1-800-654-3545 |
| 3. General Product Information | www.marleymep.com |

Note: When obtaining service always have the following:

1. Model number of the product
2. Date of manufacture
3. Part number or description

Note: Do not return to manufacturer.



Marley[®]
Engineered Products

470 Beauty Spot Rd. East
Bennettsville, SC 29512 USA