



**Marley**<sup>®</sup>  
Engineered Products

## Industrial Infrared Heater Disconnect, Tipover, and Ground Fault Accessories

# Installation & Maintenance Instructions

Dear Owner,

*Congratulations! Thank you for purchasing these accessories by Marley Engineered Products. You have made a wise investment selecting the highest quality product in the heating industry. Please carefully read the installation and maintenance instructions shown in this manual. You should enjoy years of efficient heating comfort with this product from Marley Engineered Products... the industry's leader in design, manufacturing, quality and service.*

*... The Employees of  
Marley Engineered Products*

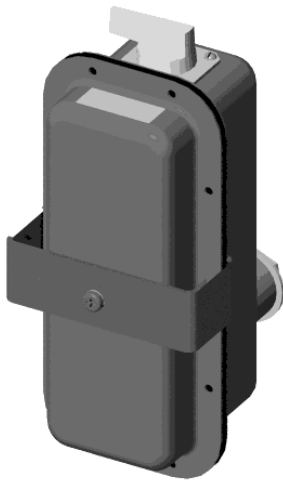

Model PDS60050

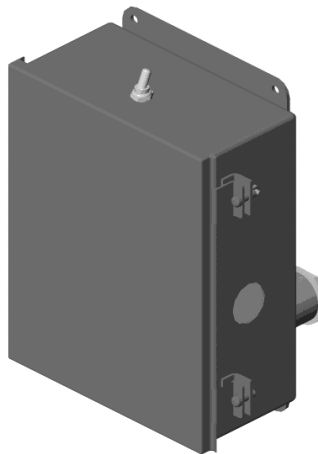

Model TOS240  
TOS480



WMGF240  
WMGF480

### **⚠ WARNING**

**ELECTRIC SHOCK HAZARD. Disconnect all power to heater before installing or servicing kit(s). Failure to do so could result in personal injury or property damage. Kit(s) must be installed by a qualified person in accordance with the National Electrical Code, NFPA 70.**

**Always check to make certain the voltage rating of the kit matches the voltage rating of the heater (See Nameplates).**

### GENERAL

To use this instruction sheet from Table 1 select the Installation Instructions by matching the Kit Model to the Heater Model. If a match does not exist consult Factory.

The kits are add-on options to BRM or XRM Radiant Heaters. The installation and renewal parts identification for the heater is covered in the instruction sheet provided with the heater. **SAVE BOTH COPIES OF THE INSTRUCTION SHEET.**

Table 1

Kit Model	Used with Heater Model	Kit Function	Installation Instructions	Wiring Diagram
PDS60050	BRM/XRM Fixed	Adds Integral Disconnect Switch	See Page 2	Fig. 1
PDS60050	BRM/XRM Portable	Adds Integral Disconnect Switch	See Page 3	Fig. 1
WMGF240 / WMGF480	BRM/XRM Series	Adds Wall Mounted Ground Fault Sensor	See Page 4	Fig. 2
TOS240 / TOS480	BRM/XRM Series	Adds Tip Over Shut Down	See Page 5	Fig. 3

## INSTALLATION INSTRUCTIONS

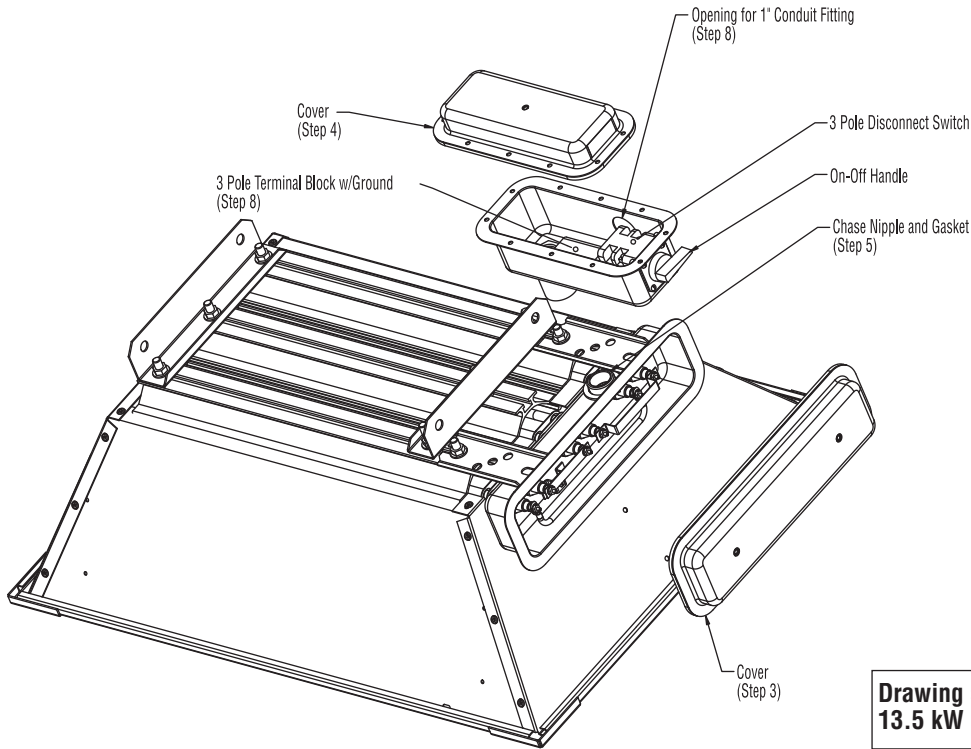

**Drawing shows 6 kW heater.  
13.5 kW heater steps are identical.**

### INSTRUCTIONS FOR INSTALLING DISCONNECT SWITCH ON 6 AND 13.5 KW FIXED RADIANT HEATERS

1. Addition of the disconnect switch assy must be done by a qualified electrician.
2. The disconnect switch kit includes the following parts.  
Verify that all parts are included, if not, contact the Marley Service Dept.
  - (1) Disconnect Switch Assy
  - (2) Mounting Bracket (Not Used)
  - (3) Hardware Kit: (Not Used)
    - Two 3/8" Lockwashers
    - Two 3/8" Nuts
    - One Self Tapping Screw
    - One Gasket for Cord Fitting (Supplied Separately)
3. Remove the screws in the heater terminal box. Remove cover.
4. Remove cover from disconnect switch assy using same method as Step 3.
5. Remove Chase nipple and gasket from opening end of disconnect switch assy. Slide Chase nipple through hole in heater terminal box and then gasket over threads.
6. Thread Chase nipple into threaded coupling. Wrench tighten nipple.
7. Uncoil three (3) leads marked "1", "2", and "3" located in disconnect switch housing. Thread these three (3) leads through the nipple. Attach leads to the terminals indicated on the heater wiring label located on the cover of the heater. If using for single phase, cap off lead marked "3".
8. Attach conduit to the opening in the disconnect switch housing. Connect leads to terminal block.
9. Inspect all wiring to make sure all connections are tight, adequate electrical clearances exist, and all electrical practices are met.
10. Install both covers.

## INSTALLATION INSTRUCTIONS

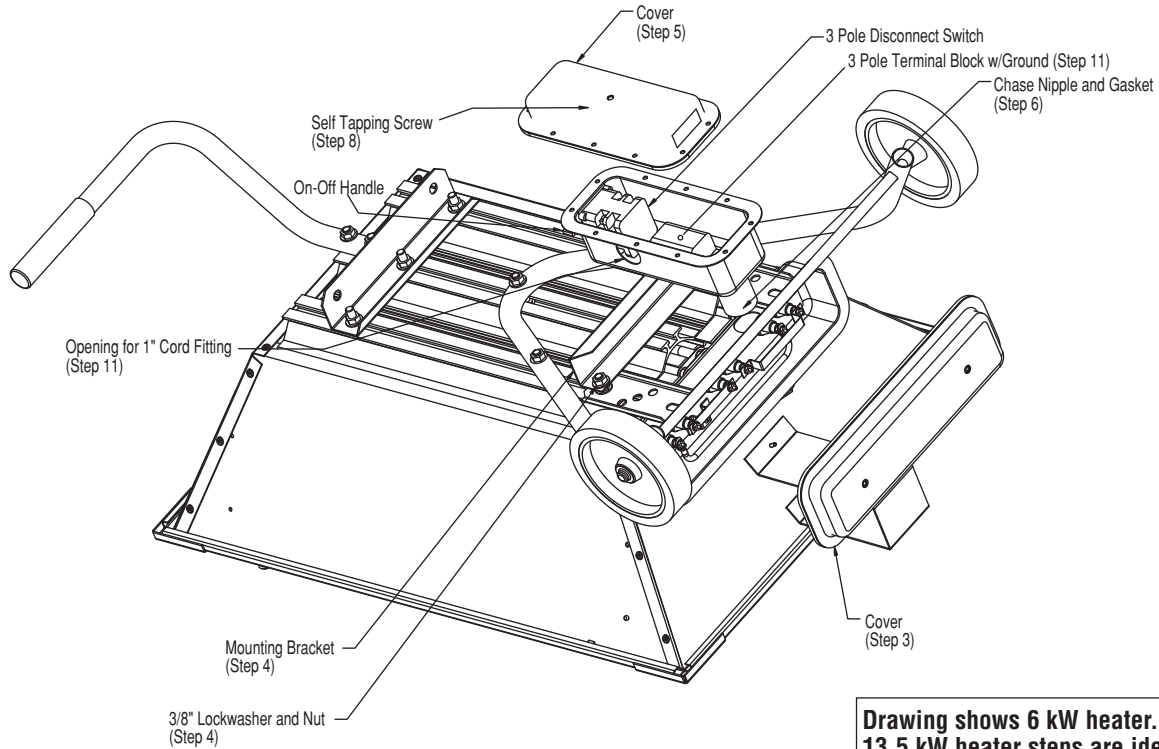

### INSTRUCTIONS FOR INSTALLING DISCONNECT SWITCH ON 6 AND 13.5 KW PORTABLE RADIANT HEATERS

1. Addition of the disconnect switch assy must be done by a qualified electrician.
2. The disconnect switch kit includes the following parts.  
Verify that all parts are included, if not, contact the Marley Service Dept.
  - (1) Disconnect Switch Assy
  - (2) Mounting Bracket
  - (3) Hardware Kit:
    - Two 3/8" Lockwashers
    - Two 3/8" Nuts
    - One Self Tapping Screw
    - One Gasket for Cord Fitting (Supplied Separately)
3. Remove the screws in the heater terminal box. Remove cover.
4. Place mounting bracket over 3/8" studs as shown. Place lockwashers on studs and secure in place with 3/8" nuts.
5. Remove cover from disconnect switch assy using same method as Step 3.
6. Remove Chase nipple and gasket from opening end of disconnect switch assy. Slide Chase nipple through hole in heater terminal box and then gasket over threads.
7. Thread Chase nipple into threaded coupling. Hand tighten only.
8. Line up hole in bottom of disconnect switch housing with hole in mounting bracket. Tap 10-32 x 1/2" long screw into mounting bracket.
9. Wrench tighten Chase nipple installed in Step 6.
10. Uncoil three (3) leads marked "1", "2", and "3" located in disconnect switch housing. Thread these three (3) leads through the nipple. Attach leads to the terminals indicated on the heater wiring label located on the cover of the heater. If using for single phase, cap off lead marked "3".
11. Attach cord assy to the opening in the disconnect switch housing. Connect leads of cord to terminal block.
12. Inspect all wiring to make sure all connections are tight, adequate electrical clearances exist, and all electrical practices are met.
13. Install both covers.

## INSTRUCTIONS FOR INSTALLING WALL MOUNTED GROUND FAULT ACCESSORY

1. Check voltage on heater nameplate and WMGF to make certain voltages are the same. If voltages do not match, consult factory.
2. The WMGF will provide ground fault protection for BRM/XRM Radiant heaters. The number of heaters serviced by one (1) WMGF is dependent on the number and length of the heating elements. See Table 2.
3. See Instruction Sheet (provided with heater) for IMPORTANT INSTRUCTIONS and WIRING.
4. Using the WMGF as a template mark mounting holes on wall. Use an anchoring method adequate to support the weight.
5. Wire between WMGF and heater, wire to terminal block. Service entrance wiring to be made to contactor connectors.
6. The ground fault sensor has been factory set at .03 Amps, **DO NOT CHANGE THE SETTING.**

Table 2

Heater Model	Max. No. of Heaters
M2000	6
M4500	3
M6000	2
M13500	1

WMGF Mounting Dimensions

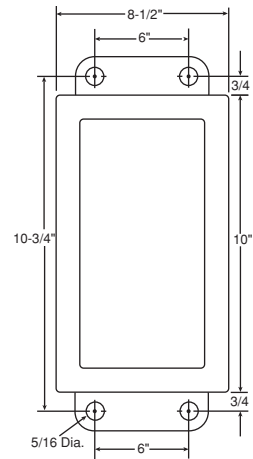

## MAINTENANCE

The ground fault sensor provides a reliable and cost effective method for sensing ground faults. The purpose is to monitor for ground faults, sense potential heater failure symptoms and to protect equipment.

The current-carrying wires are routed through the current transformer on the control. When ground current reaches the level set by the trip point adjustment, (.03 Amps), the relay trips, illuminates the tripped LED and provides an output signal which de-energizes the magnetic contactor.

### ⚠ WARNING

**ELECTRIC SHOCK HAZARD. Disconnect all power to heater before installing or servicing kit(s). Failure to do so could result in per-**

**sonal injury or property damage. Kit(s) must be installed by a qualified person in accordance with the National Electrical Code, NFPA 70.**

If heating element(s) fail to operate:

1. Open door of enclosure. **DANGER: Hazard of Electric Shock.** If "Tripped" indicator is on, this indicates one or more heating elements are about to fail. Disconnect power and follow the GF Troubleshooting Diagram below.
2. If the "Tripped" indicator is not on, check for blown fuses or failed components within the heater's electrical system.

### GF TROUBLESHOOTING DIAGRAM

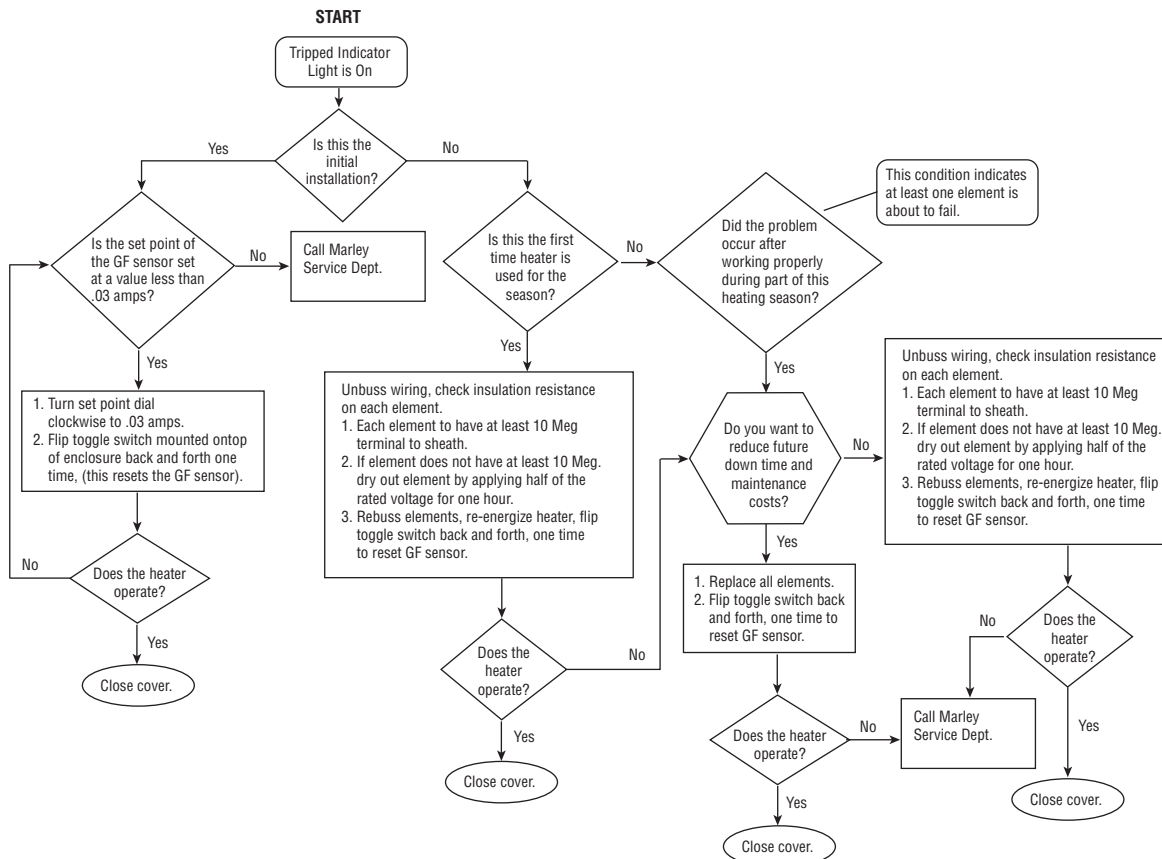

## INSTALLATION INSTRUCTIONS

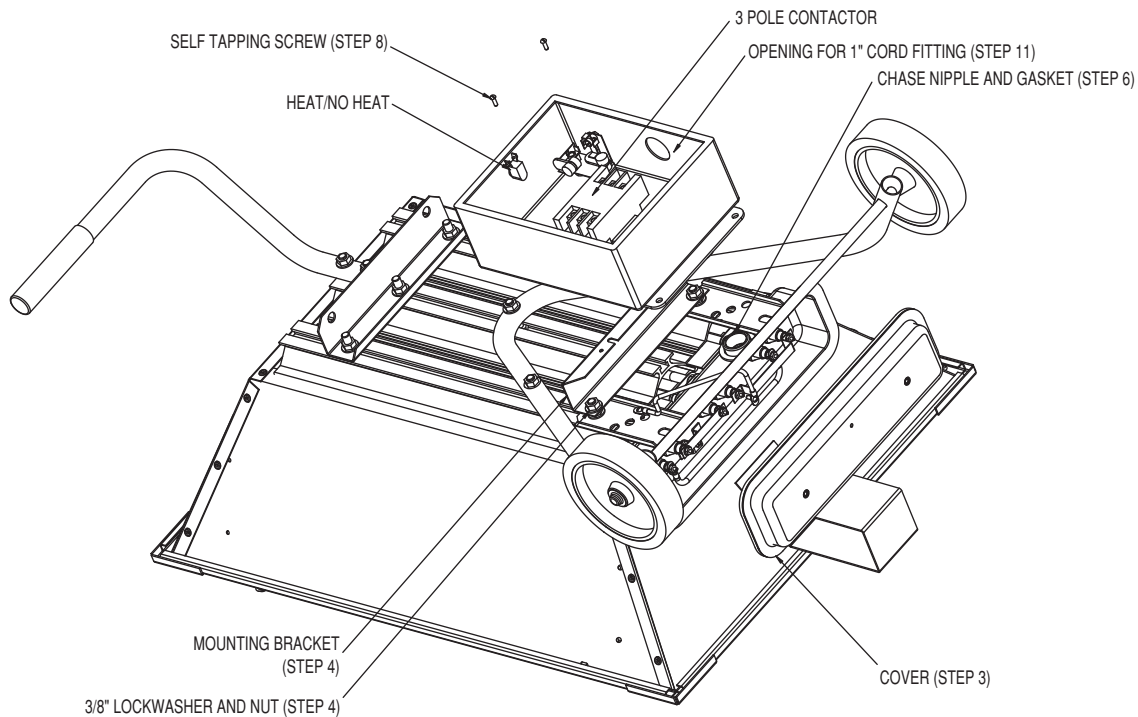

VIEW SHOWN WITH TIP OVER SWITCH ASSY COVER REMOVED

**Drawing shows 6 kW heater.  
13.5 kW heater steps are identical.**

### INSTRUCTIONS FOR INSTALLING TIP OVER SWITCH ON 6 AND 13.5 KW PORTABLE RADIANT HEATERS

1. Addition of the tip over switch assy must be done by a qualified electrician.
2. The tip over switch assy includes the following parts.  
Verify that all parts are included, if not, contact the Marley Service Dept.
  - (1) Tip Over Switch Assy
  - (2) Mounting Bracket
  - (3) Hardware Kit:
    - Two 3/8" Lockwashers
    - Two 3/8" Nuts
    - Two Self Tapping Screw
    - One Gasket for Cord Fitting (Supplied Separately)
3. Remove the screws in the heater terminal box. Remove cover.
4. Place mounting bracket over 3/8" studs as shown. Place lockwashers on studs and secure in place with 3/8" nuts.
5. Remove cover from tip over switch assy using same method as Step 3.
6. Remove Chase nipple and gasket from open end of tip over switch assy. Slide Chase nipple through hole in heater terminal box and then gasket over threads.
7. Thread Chase nipple into threaded coupling. Hand tighten nipple.
8. Line up hole in bottom of tip over switch with hole in mounting bracket. Tap 10-32 x 1/2" long screws into mounting bracket.
9. Wrench tightened Chase nipple installed in Step 6.
10. Uncoil three (3) leads marked "1", "2", and "3" located in disconnect switch housing. Thread these three (3) leads through the nipple. Wire nut leads of tip over switch to leads of heater. If using for single phase, cap off lead marked "3".
11. Attach cord assembly to the opening in the tip over switch housing. Connect leads of cord to the contactor.
12. Inspect all wiring to make sure all connections are tight, adequate electrical clearances exist, and all electrical practices are met.
13. Install both covers.

## MAINTENANCE

The tip over cutout provides a reliable and cost effective method to shut off the heater in case of tip-over.

### **WARNING**

***ELECTRIC SHOCK HAZARD. Disconnect all power to heater before installing or servicing kit(s). Failure to do so could result in personal injury or property damage. Kit(s) must be installed by a qualified person in accordance with the National Electrical Code, NFPA 70.***

If heating element(s) fail to operate:

1. Open door of enclosure. **DANGER: Hazard of Electric Shock.**
2. If "Tripped" indicator is not on, check for blown fuses or failed electrical components in the heater's electrical system including the tip over trip mechanism. then this indicates one or more heating elements are about to fail.
3. Check pendulums on the tip over switch mechanisms to be sure they are not blocked.
4. If the "Tripped" indicator is on, then this indicates one or more heating elements are about to fail. Disconnect power and follow the GF Troubleshooting Diagram below.

# WIRING

For applicable wiring diagram see Table 1

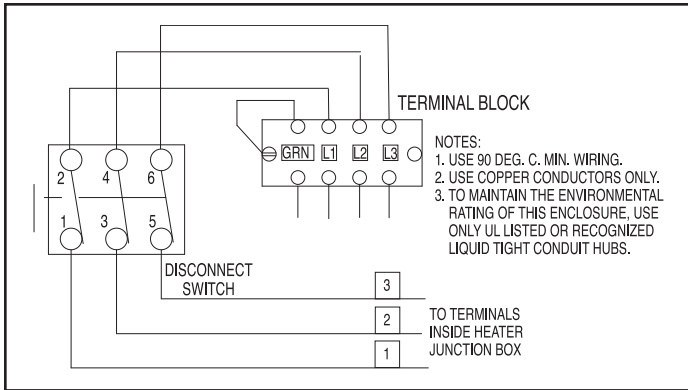

Fig. 1

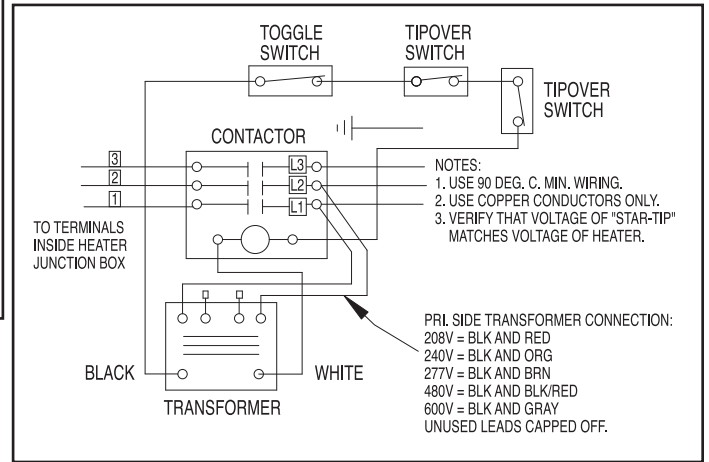

Fig. 3

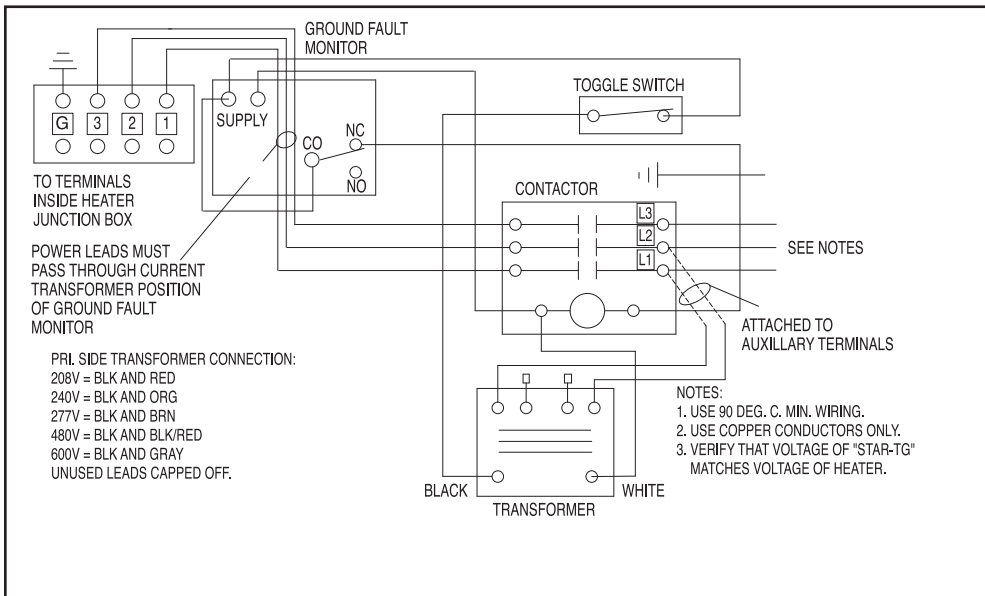

Fig. 2

#### LIMITED WARRANTY

All products manufactured by Marley Engineered Products are warranted against defects in workmanship and materials for one year from date of installation. This warranty does not apply to damage from accident, misuse, or alteration; nor where the connected voltage is more than 5% above the nameplate voltage; nor to equipment improperly installed or wired or maintained in violation of the product's installation instructions. All claims for warranty work must be accompanied by proof of the date of installation.

The customer shall be responsible for all costs incurred in the removal or reinstallation of products, including labor costs, and shipping costs incurred to return products to Marley Engineered Products Service Center. Within the limitations of this warranty, inoperative units should be returned to the nearest Marley authorized service center or the Marley Engineered Products Service Center, and we will repair or replace, at our option, at no charge to you with return freight paid by Marley. It is agreed that such repair or replacement is the exclusive remedy available from Marley Engineered Products.

THE ABOVE WARRANTIES ARE IN LIEU OF ALL OTHER WARRANTIES EXPRESSED OR IMPLIED, AND ALL IMPLIED WARRANTIES OF MERCHANTABILITY AND FITNESS FOR A PARTICULAR PURPOSE WHICH EXCEED THE AFORESAID EXPRESSED WARRANTIES ARE HEREBY DISCLAIMED AND EXCLUDED FROM THIS AGREEMENT. MARLEY ENGINEERED PRODUCTS SHALL NOT BE LIABLE FOR CONSEQUENTIAL DAMAGES ARISING WITH RESPECT TO THE PRODUCT, WHETHER BASED UPON NEGLIGENCE, TORT, STRICT LIABILITY, OR CONTRACT.

Some states do not allow the exclusion or limitation of incidental or consequential damages, so the above exclusion or limitation may not apply to you. This warranty gives you specific legal rights, and you may also have other rights which vary from state to state.

For the address of your nearest authorized service center, contact Marley Engineered Products in Bennettsville, SC, at 1-800-642-4328. Merchandise returned to the factory must be accompanied by a return authorization and service identification tag, both available from Marley Engineered Products. When requesting return authorization, include all catalog numbers shown on the products.



470 Beauty Spot Rd. East  
Bennettsville, SC 29512 USA