

Product Name

Open Coil Electric Duct Heater

Manufacturer

Marley Engineered Products
470 Beauty Spot Road East
Bennettsville, South Carolina 29512
Phone: 843-479-4006
Email: webmaster@marleymep.com
Web: MarleyMEP.com

Product Description

Basic Use

The Open Coil Duct Heater, brings innovation and flexibility to the electric duct heat market. This series is UL, eETLus, and cULus tested and approved and include symmetrical design features that provide flexibility during installation at a project or work site.

Duct heaters are used in forced air applications to provide standalone space heat or to supplement existing heating systems.

Installation examples:

- Space heating
- Multi-zone or VAV
- Primary heating
- Replacement of existing
- Reheat
- Secondary/auxiliary heating

For Open Coil Electric Duct Heat Models

- Maximum Outlet Air Temp: 148 degrees F
- Maximum Heater KW: 30 KW per ft² of duct cross section

All models may be flipped and rotated as long as the diffuser/radiant screen is moved to the inlet air side where applicable.

Minimum Required Airflow is based on Inlet Air Temperature, see airflow chart for supporting reference material on the last page of this document.

Composition and Materials

All sheet metal housing. 0.034+.008/-.00 minimum spangle galvanized sheet steel grade G-90.

Standard Features:

- Open-coil element
- Grounding lugs
- Airflow switch
- Detailed wiring diagram
- Control terminal board



Flippable Electric Heater



Flippable Electric Heater

- Power fusing over 48 amps included
- A disconnecting magnetic control contactor per stage or each 48-amp circuit within a stage
- Automatic high-limit switch for primary over-temperature protection
- Manual reset high-limit switch for secondary over-temperature protection
- The wire rack element suspension system allows for a low pressure drop across the coils
- In horizontal applications, airflow can travel in either direction without any modification, allowing for easy field modifications
- Control box features hinge and latch for easy access

Benefits and Advantages:

- Patent pending flippable design
- Symmetrical design; fewer part numbers, easier site installation
- UL, cETLus and cULus tested and approved
- Better heater coverage
- Lower coil watt density

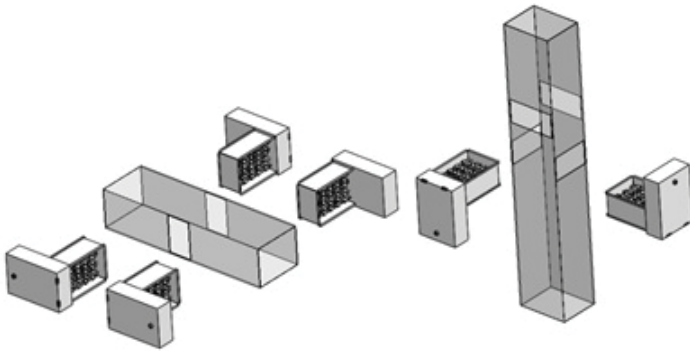

Horizontal and Vertical Orientations

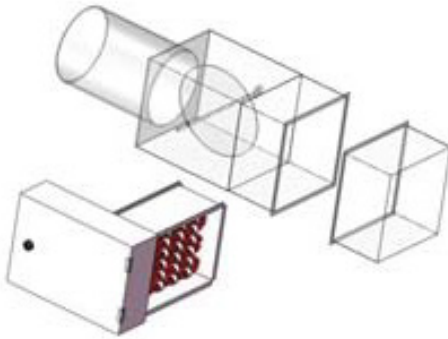

Option- Flange mount

- Design program offers wider distribution of kilowatt sizes
- The rugged, efficient, open frame duct heaters offers the capability to heat large volumes of air with fast warm-ups and cool-downs
- Our open design provides low pressure drops with no build up of excessive temperatures and the low static pressures allow you to use smaller, more economical blowers
- A range of sizes are available to meet your specific need
- Flippable; can be installed six different ways

Types

Two frame types are available: slip in and flange.
(See Drawing 1)

Models

Open Coil Electric Duct Heat slip in model duct heaters for horizontal and vertical applications. Standard low watt density coil

Limitations

The Open Coil Electric Duct Heater is designed for indoor ductwork installation only. Consult the factory for optional solutions.

Accessories/Options

All are separate accessories depending on configuration. Wall thermostat, control transformer, main power terminal block, heater interlock, silicon controlled rectifier (SCR), and disconnect switch.

Technical Data

Applicable Standards

Canadian UL (cULus)

CSA C22.2

Electrical Testing Labs (ETL)

ETL Report No. 100147043CRT-002
(Control No. 3124970)

UL International

U L File Number: E33341

UL1996

Installation

Inspect heater for any possible damage. Check all insulators for breakage and inspect heater element wire(s) for any deformation or damage that could cause a short circuit to ground. Make sure all fasteners are tight. Electrical connections such as pressure terminals should be checked for tightness.

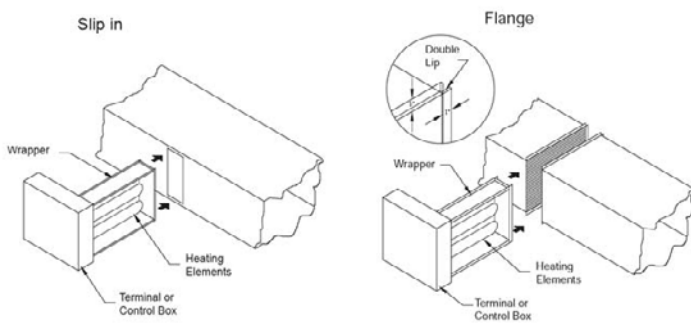

Drawing 1: Slip in and flange frame types

General Operating Requirements:

- Maximum Outlet air Temp: 148 degrees F
- Maximum heater KW: 16.5 KW per square foot of duct cross section

Minimum air flow or greater must be maintained uniformly over the entire face of the heater. The velocity of air should NEVER be lower than the specified minimum. In cases where this is not true the KW must be reduced or the velocity of air increased.

Observe at least one heating cycle to insure that cycling of safety limit controls does not occur under normal operating conditions before leaving the installation.

Refer to attached wiring diagram and wiring diagram on inside of cover. Make sure line and control voltage of system matches that noted on wiring diagram.

Wire in accordance with N.E.C. and any existing local codes. Check tightness of all factory and field electrical connections. Make sure fan interlock is wired in if the heater does not have an air flow switch. Use 90 degree C (194 deg. F) copper wire. Control must be wired for N.E.C. Class 1 unless otherwise specified.

When heater has integral transformer for control voltage to thermostat, use thermostat with isolating contacts to prevent interconnection of class 2 outputs.

Disconnect all electrical power before servicing. When servicing heater, make sure all components are repositioned in the proper location and reconnect per wiring diagram. Replacement parts must be identical to the original components. Contact factory for replacement parts.

For Open Coil Electric Duct Heater model heaters which may be installed in horizontal or vertical ducts, the following instructions must be followed for safe and optimal performance.

1. Install heater a minimum of four feet from heat pumps or central air conditioners.
2. Install at least four feet downstream of an air handler.
3. Install at least two feet either side from an elbow or turn.
4. Install at least four feet from any canvas duct connector or transition section or change in duct size.
5. Install at least four feet downstream from an air filter.
6. Install at least four feet upstream from a humidifier.

Refer to Electrical Requirements section and General Operating Requirements, Flip-able Installation Manual sections for additional requirements.

For Open Coil Electric Duct Heater slip in models with horizontal and vertical applications the following instructions must be followed for safe and optimal performance.

To install cut an opening in the duct of the appropriate size to allow the heater to slip in while maintaining a proper mounting and sealing surface. Insert the heater and use the heater box as a template for the mounting screw locations. Remove heater and drill mounting holes. Mount unit to duct using sheet metal screws. Large heaters may require hangers. Connect high and low voltage supplies as required.

For Open Coil Electric Duct Heater flange mount models insert the heater between two sections of flanged duct and bolt into place. For additional strength the duct flange(s) should be doubled. Large heaters may require hangers. Connect high and low voltage supplies as required.

For Open Coil Electric Duct Heater models with an optional diffuser/radiant screen that must be rotated move the air diffuser/radiant screen to the opposite side such that it is on the inlet air side of the heater. For heaters with no diffuser simply flip or rotate as needed.

For Open Coil Electric Duct Heater model duct heaters in horizontal or vertical applications the air duct should be installed in accordance with the Standards of the National Fire Protection Agency for the Installation of Air Conditioning and Ventilating Systems (Pamphlet No. 90A) and Warm Air Heating and Air Conditioning Systems (Pamphlet No. 90B). Available from NFPA.

Additionally, do not "bank" heaters (side-by-side). If greater capacity is required, proportion smaller heaters in separate runouts. Heater control boxes must be completely accessible and located to provide ventilation at all times.

Availability and Cost

Availability

Eleven day standard lead time

Cost

Please contact sales representative for pricing information.

Warranty

MEP offers a limited 18 month warranty. Please contact manufacturer for complete warranty information.

Maintenance

Open Coil Electric Duct Heater duct heaters do not require any specialized preventative maintenance other than electrical connections should be checked for tightness annually, a periodic visual inspection, and any filters associated with the system should be changed at regular intervals.

Technical Services

Manufacturer provides direct engineering/technical support.

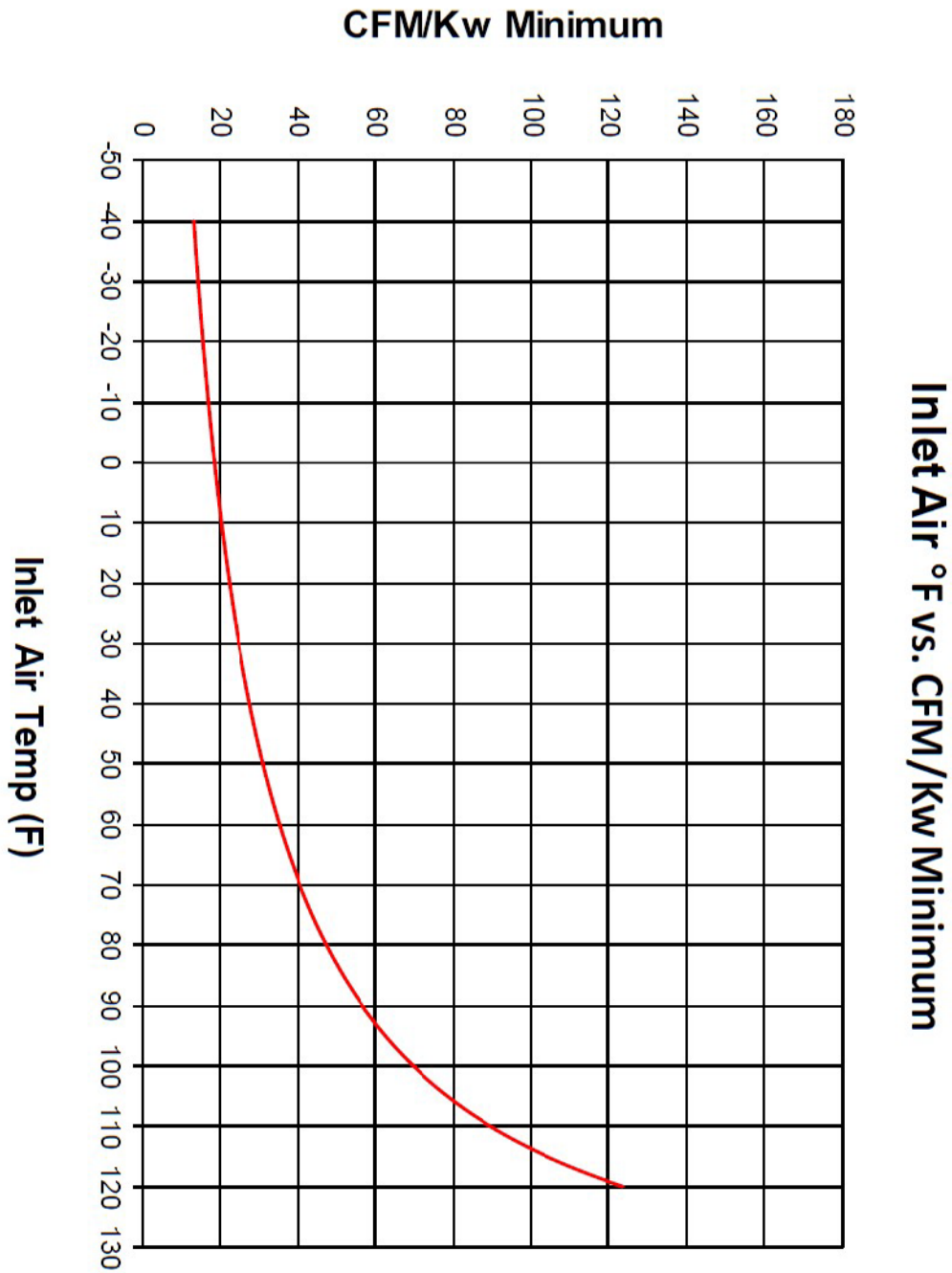

Notes:
 Chart is Based on
 Minimum Airflow and
 Max Outlet Air Temp of
 148°F
 Max Recommended Air
 Velocity is 2000 FPM

