

Flip-able Slip-in Duct Heaters

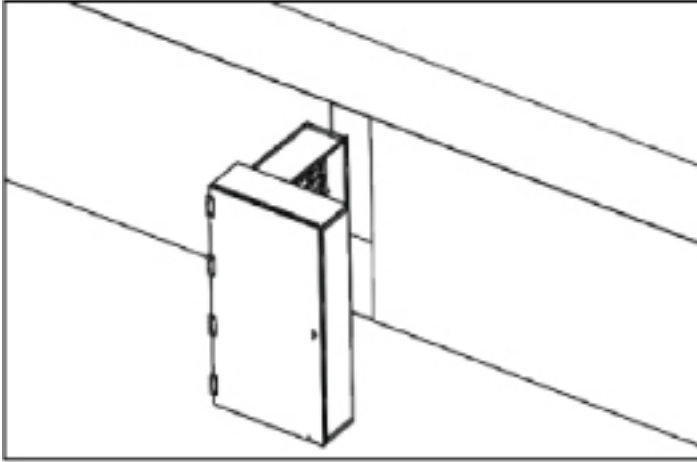

General inspections, all models:

1. Before Installation, inspect the heater for possible shipping or handling damage.
2. Check all electrical insulators and inspect heater element wire(s) for any damage.
3. Make sure all fasteners are tight.
4. Check that all electrical connections are tight.

Operating requirements

Note: UL Listing and Product Warranty are voided if the following installation requirements are not met.

Open Coil Model

Minimum Air Velocity: See Fig 2

Maximum Inlet Air Temp: 110 Deg. F Maximum
Heater KW: 30 KW per sq ft of duct cross section.
See Figure 3

Note: Minimum air flow or greater must be uniformly maintained over the heating elements. The velocity of air should NEVER be lower than the specified minimum. If air flow is lower than the minimum, the KW must be reduced in order to avoid heater element overshoot failures.

Note: It is recommended to observe at least one heating cycle to

insure normal operation of the heater and safety limit controls.

Heater installation & preparations

1. Inspect the duct work to make sure the area is free of obstacles and wiring before cutting the mounting hole.
2. To install, cut an appropriate sized opening in the duct to allow the heater to tightly slip in.
3. Insert the heater and use the heater box as a template for the mounting screw locations.
4. Remove heater and drill mounting holes.
5. Re-insert the heater and mount to the duct using sheet metal screws.
6. For safety, use hangers on larger heaters.
7. While power is disconnected, terminate all high and low voltage supply lines.
8. For all models with an optional diffuser/radiant screen, the screen must be mounted on the air inlet air side of the heater. Flipped or rotated as shown in figure 1.
9. All duct heaters should be installed in accordance with the Standards of the National Fire Protection Agency for the Installation of Air Conditioning and Ventilating Systems (Pamphlet No. 90A) and Warm Air Heating and Air Conditioning Systems (Pamphlet No. 90B).
10. Do not "Bank" heaters (side by side). If greater capacity is required, use multiple smaller duct heaters in separate runouts.
11. All heater control boxes must be completely accessible and ventilated at all times. Do not block control panel venting.

Note: Maintaining a proper mounting and sealing of the heater and duct surface is important.



Electrical Requirements

1. Disconnect all electrical power before servicing.
2. Refer to the wiring diagram on inside of cover of the heater control box.
3. When servicing the heater, make sure all components are repositioned in the proper location and reconnect per the wiring diagram.
4. Make sure line and control voltage of system matches that noted on wiring diagram.
5. Wire in accordance with N.E.C. and any existing local codes.
6. Check tightness of all factory and field electrical connections.
7. If the heater does not have an air flow switch, please make sure a fan interlock is wired.
8. Use 90°C (194 deg. F) copper wire.
9. Control must be wired for N.E.C. Class 1 unless otherwise specified.
10. If the heater has an integral transformer for control voltage to a thermostat, use a thermostat with isolating contacts to prevent interconnection of class 2 outputs.
11. Replacement parts must be identical to the original components.
12. Contact factory for all replacement parts.

Note: As with all electrical connections, safety precautions must be taken to avoid injury or electrocution. Please be safe!

Installation of Open Coil Duct Heaters

For Open Coil Electric Duct Heaters that are installed horizontally or vertically in duct spaces, the following instructions must be followed for safe and optimal performance.

1. Install heater a minimum of (4) feet from heat pumps or central air conditioners.
2. Install at least (4) feet downstream from an air handler.
3. Install at least (2) feet either side from an elbow or turn.
4. Install at least (4) feet from any canvas duct connector or transition section for change in duct size.
5. Install at least (4) feet downstream from an air filter.
6. Install at least (4) feet upstream from a humidifier.

Note: Refer to Electrical Requirements section and Operating Requirements section for additional requirements.

Note: All Models may be flipped and rotated as long as the diffuser/radiant screen is moved to the inlet air side when applicable. Refer to figure 1 for flip-able possibilities.



Figure 1

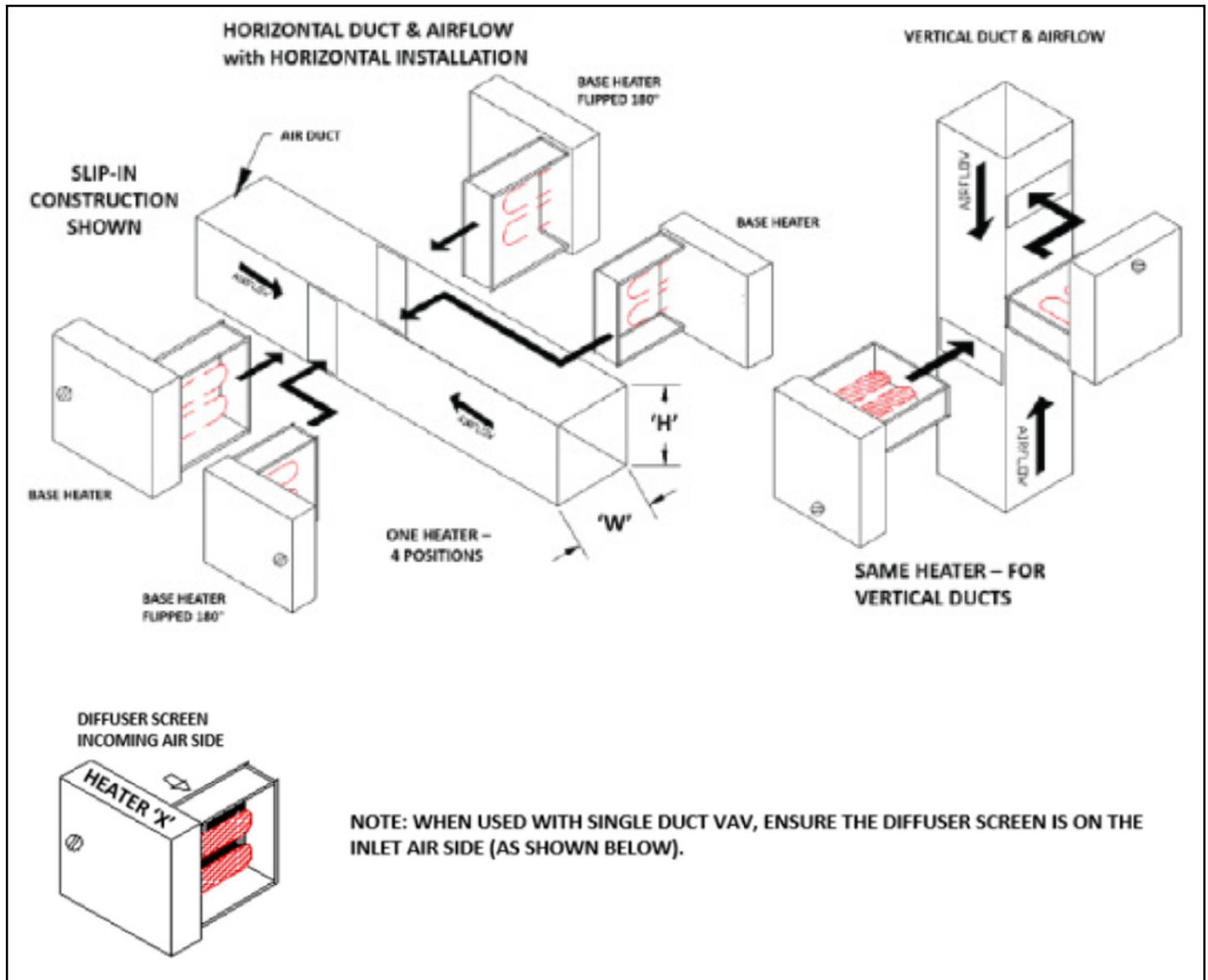

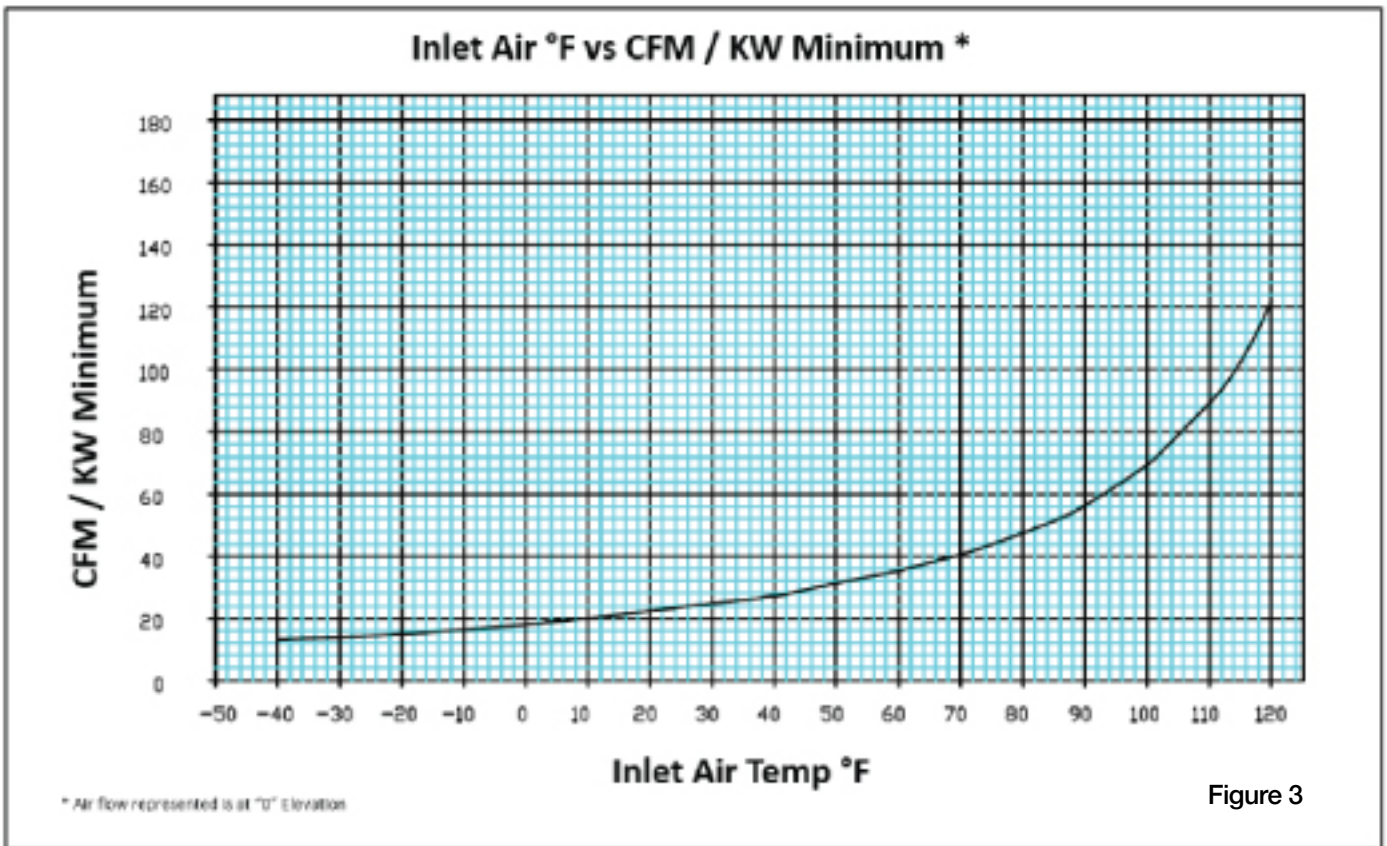
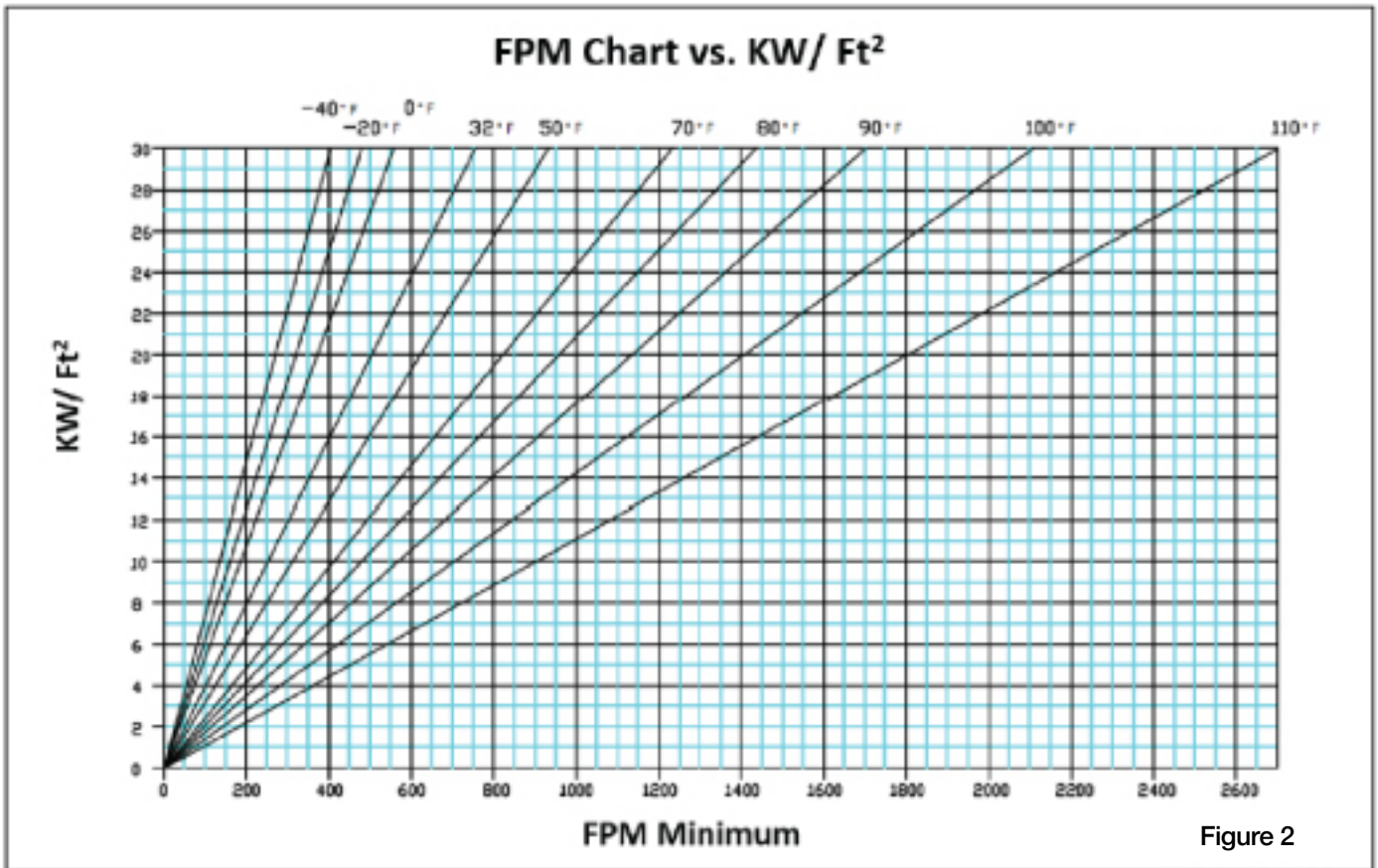



FOR STANDARD NON-SSR HEATERS ONLY!

CONTROL FOR HEATERS WITHOUT INTERNAL TRANSFORMER (REQUIRES 24 VAC)*

THESE HEATERS WILL REQUIRE A THERMOSTAT THAT CAN PROVIDE A 24 VAC* SIGNAL TO CONTROL THE HEATER STAGING.

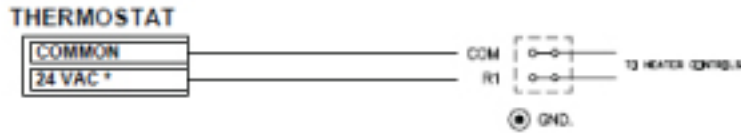

CONTROL FOR HEATERS WITH INTERNAL TRANSFORMER *

THE HEATER'S TRANSFORMER CAN POWER ALL OF ITS OWN CONTROLS . A DRY CONTACT THAT CONNECTS COMMON TO R1, R2, ETC. IS ALL THAT IS REQUIRED TO TURN THIS TYPE OF HEATER ON/OFF.

INTERNAL TRANSFORMER CAN BE USED TO POWER THE THERMOSTAT IF NEEDED

NOTE: BE CAREFUL NOT TO OVERLOAD TRANSFORMER WITH THINGS SUCH AS EXTERNAL LOADS, EXTRA LONG CONTROL WIRES, ETC. AN EXTERNAL TRANSFORMER MAY BE REQUIRED IN THESE SCENARIOS.



OPTIONAL FAN INTERLOCK ACCESSORY

THE TYPICAL FAN INTERLOCK IS A SET OF DRY CONTACTS TO OPERATE A FAN OR OTHER EXTERNAL DEVICE FOR HEATER OPERATION "CONTACTS CLOSE WHEN HEATER IS ACTIVE "

NOTE: OTHER FUNCTIONS ARE AVAILABLE UPON REQUEST.



OPTIONAL FAN INTERLOCK EM STYLE

THE FAN INTERLOCK "EM" STYLE REQUIRES 24 VAC * FROM A FAN MOTOR (OR EQUIVALENT) TO ENABLE HEATER OPERATION. "APPLY VOLTAGE TO ENABLE HEATER, REMOVE VOLTAGE TO DISABLE HEATER"

NOTE: OTHER FUNCTIONS ARE AVAILABLE UPON REQUEST.



* 24VAC CONTROL VOLTAGE IS STANDARD UNLESS ALTERNATE IS CHOSEN (120VAC, 277VAC, ETC...)





FOR HEATERS EQUIPPED WITH SSR'S ONLY!

**INSTALLATION DETAILS FOR
ELECTRIC DUCT HEATERS
EQUIPPED WITH SSR'S OR
ELECTRONIC STEP CONTROLLERS
(INCLUDING SSR VERNIER CONTROL)**

SSR HEATERS ARE DESIGNED TO ACCEPT AN ANALOG CONTROL SIGNAL. THE HEATER WILL NEED TO BE SUPPLIED WITH EITHER A 0(2)-10 VDC OR A 4-20 mA SIGNAL.

SSR HEATERS WILL NOT OPERATE WITH A STANDARD 24 VAC CONTROL SIGNAL.

DO NOT ADJUST ANY DIP SWITCHES ON THE CONTROLS WITHIN THE HEATER!

THEY ARE FACTORY SET-CONTROL SIGNAL IS DETERMINED BY INTERFACE MODULE CONNECTION.

**INTERFACE MODULE CONTROL
SIGNAL WIRING CONNECTION
DIAGRAM**

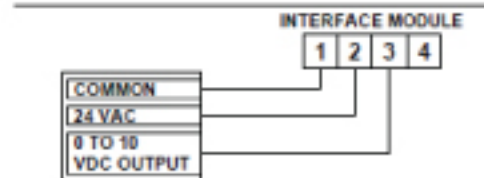

2 TO 10 VDC
STAND ALONE THERMOSTAT

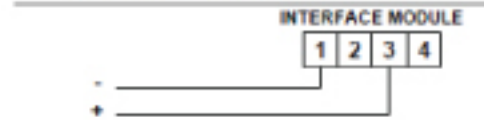

2 TO 10 VDC FROM
D.D.C. BUILDING AUTOMATION SYSTEM

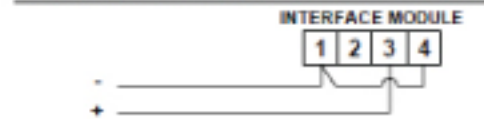

4 TO 20 mA FROM D.D.C.
BUILDING AUTOMATION SYSTEM

**INTERCONNECTION OF A STAND ALONE
THERMOSTAT AND A DUCT HEATER WITH
ELECTRONIC STEP CONTROLLER OR SSR CONTROL**

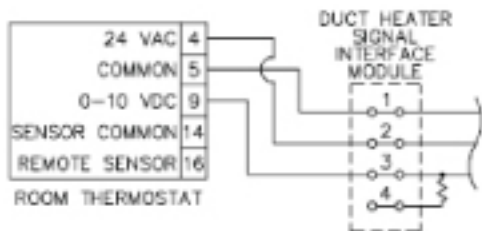

WITHOUT REMOTE SENSOR

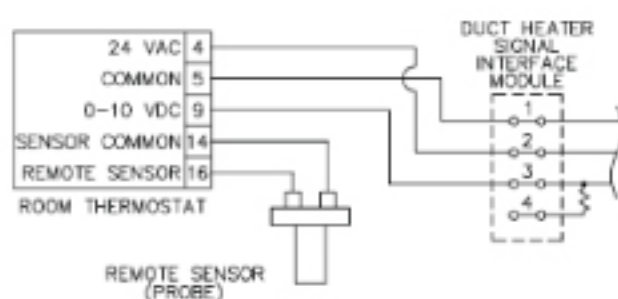

WITH REMOTE SENSOR

