

QMKC SERIES

Commercial Baseboard Heater

BASEBOARD



Ideal Spaces:

Bedrooms
Living/Family Room
Kitchens
Bathrooms
Basements
Offices
Conference Rooms
Hallways
Waiting Rooms

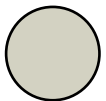

Beige

- › Ideal for basic, zoned primary/secondary heating
- › No fans; convection heat minimizes air flow, reducing flow of bacteria and dust
- › Commercial-grade 18-gauge cold rolled front cover and brackets allow heater to withstand rigors of commercial applications
- › Steel-sheathed heating element combines the durability of a steel tubular heater with the excellent heat transfer characteristics of aluminum fins
- › Built-in wire-way facilitates end-to-end installation of continuous-run heaters
- › Large, pre-wired junction boxes at each end are provided with knockouts in the rear, bottom, inside and outside
- › High temperature safety limit for added protection in case of airflow blockage
- › Pre-notched marks for mounting guide
- › UL-listed for installation flush to any wall and flat on any floor type
- › Chimney-fin element designed for maximum air circulation
- › Air flow directed away from walls to help prevent wall streaking



QMKC SERIES

Commercial Baseboard Heater

Scan the QR code to access additional specs and features



Models & Specifications:

ITEM INFORMATION			ELECTRICAL DATA			DIMENSIONAL DATA	
CATALOG NO.	UPC		VOLTS	WATTS	AMPS	LENGTH	SHIP WT.
● QMKC25126W	685360060460		120	500	4.2	30"	7.8 lbs
● QMKC25026W	685360060163		208	500	2.4		
● QMKC25426W	685360060873		240/208	500/376	2.1/1.8		
● QMKC25726W	685360061320		277/240/208	500/376/282	1.8/1.6/1.4		
● QMKC2513W	685360060514		120	750	6.5	36"	9.0 lbs
● QMKC2503W	685360060217		208	750	3.6		
● QMKC2543W	685360060927		240/208	750/564	3.1/2.7		
● QMKC2573W	685360061375		277/240/208	750/564/423	2.7/2.4/2.0		
● QMKC2514W	685360060569		120	1000	8.3	48"	11.5 lbs
● QMKC2504W	685360060262		208	1000	4.8		
● QMKC2544W	685360060972		240/208	1000/752	4.2/3.6		
● QMKC2574W	685360061429		277/240/208	1000/752/564	3.6/3.1/2.7		
● QMKC2515W	685360060613		120	1250	10.4	60"	13.0 lbs
● QMKC2505W	685360060316		208	1250	6.0		
● QMKC2545W	685360061023		240/208	1250/940	5.2/4.5		
● QMKC2575W	685360061474		277/240/208	1250/940/705	4.5/3.9/3.4		
● QMKC2516W	685360060668		120	1500	12.6	72"	15.5 lbs
● QMKC2506W	685360060361		208	1500	7.2		
● QMKC2546W	685360061078		240/208	1500/1128	6.3/5.4		
● QMKC2576W	685360061528		277/240/208	1500/1128/846	5.4/4.7/4.1		
● QMKC2508W	685360060415		208	2000	9.6	96"	20 lbs
● QMKC2548W	685360061122		240/208	2000/1504	8.3/7.2		
● QMKC2578W	685360061573		277/240/208	2000/1504/1128	7.2/6.3/5.4		
● QMKC25008W	685360060118		208	2500	12.0		
● QMKC25408W	685360060828		240/208	2500/1880	10.4/8.7	96"	20 lbs
● QMKC25708W	685360061276		277/240/208	2500/1880/1410	9.0/7.5/6.8		

SKU Legend: ● = Popular Products; ● = Extended Offering (Contact your local Marley Sales Representative for typically associated lead times)

Suggested Controls



TH114A240DBA



MS26 or M601W

Filler Sections:

CATALOG NO.	UPC	DESCRIPTION	SHIP WT.
FS12	098319731500	1 ft. Filler Section	2 lbs
FS24	098319731517	2 ft. Filler Section	4 lbs
FS36	098319731524	3 ft. Filler Section	6 lbs
FS48	098319731531	4 ft. Filler Section	8 lbs
FSJ2	098319731548	2 in. Joiner Strip	.5 lbs

Blank Sections:

CATALOG NO.	UPC	DESCRIPTION	SHIP WT.
QMKCBA2W	685360059594	2.6 ft. Blank Section	4 lbs
QMKCBA3W	685360059617	3 ft. Blank Section	5 lbs
QMKCBA4W	685360059631	4 ft. Blank Section	7 lbs
QMKCBA5W	685360059655	5 ft. Blank Section	9 lbs
QMKCBA6W	685360059679	6 ft. Blank Section	11 lbs
QMKCBA8W	685360059693	8 ft. Blank Section	14 lbs

Optional Controls & Accessories:

CATALOG NO.	UPC	DESCRIPTION	SHIP WT.
TA1AW	098319730411	SP Thermostat, rated 22A @ 120-277V	1 lbs
TA1TPAW	685360185996	Tamper-Resistant Version of TA1AW	1 lbs
TA2AW	685360186009	DP Thermostat, rated 22A @ 120-277V	1 lbs
TA2TPAW	098319730442	Tamper-Resistant Version of TA2AW	1 lbs
HCA2415/20W	098319730466	240V Load Transfer Switch, 20A	1 lbs
HCA1215/20W	098319730459	120V Load Transfer Switch, 20A	1 lbs
RSA1224	098319714800	120V/24V Transformer Relay, 22A	1 lbs
RSA2024	098319714855	208V/24V Transformer Relay, 22A	1 lbs
RSA2424	098319714909	240V/24V Transformer Relay, 22A	1 lbs
RSA2724	098319714954	277V/24V Transformer Relay, 19A	1 lbs
RA1W	098319730473	120V Duplex Receptacle	1 lbs
DSW2W	685360165066	Double-Pole Power On/Off Switch rated 20A @ 120-277V	1 lbs
PR24	098319713674	Single-Pole Power Relay, 24VControl rated 30A @ 120-240V, 23A @ 277V	1 lbs
PRI20	098319713681	Same as PR24 except with 120V Control	1 lbs
ICANW	685360011097	Inside Corner	1 lbs
RA1COMPW	098319730480	Duplex Receptacle Cover only — carton of 10	1 lbs

Dimensions and Clearances:

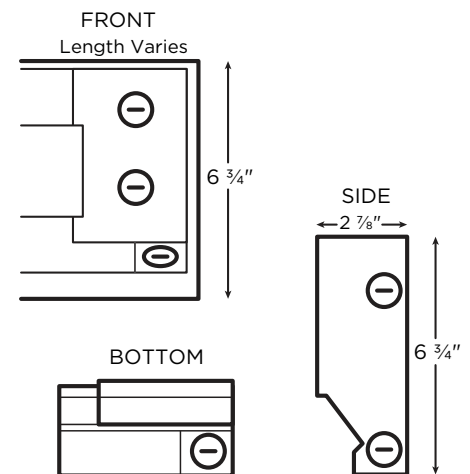

NOTE: For high-altitude baseboard heater (mounted above 7500 ft.), add suffix "H" to catalog number. 8 ft. length baseboards must be ordered in multiples of two pieces for shipment.