

# QWD SERIES

## Washdown Corrosion-Resistant Unit Heater

HARSH  
ENVIRONMENT  
PRODUCTS



### Technical Specifications:

Temp Range: 40°-120°F

CFM: 700-2400

### Ideal Spaces:

Car Washes  
Cement Plants  
Coal Handling Areas  
Dairies & Food Processing Plants  
Marine & Offshore  
Power Generating Stations  
Steel Mills & Foundries  
Swimming Pool Areas  
Wastewater Treatment Plants

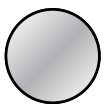

Stainless Steel

- › Watertight construction can be hosed down without disconnecting the heater
- › Corrosion-resistant stainless-steel construction, powder-coated aluminum fan blade, and nonmetallic NEMA 4X terminal enclosure
- › Built-in safety and temperature controls are included in a single package; components and motor are factory-wired to a single terminal block for field wiring

### Standard Construction Features:

- › Industrial-grade, type 316 stainless steel tubular elements with stainless steel fins
- › Heat engine secured within 16-gauge 304 stainless steel shroud.
- › Totally enclosed, epoxy coated, UL-Recognized motor with permanently lubricated ball bearings resist moisture and corrosion
- › Factory-wired to NEMA 4X enclosure.
- › Powder coated, aluminum fan blade suitable for corrosive salt spray environments.
- › Adjustable, stainless steel, louvered outlet grille can be rotated 90° to direct airflow up, down, left or right.
- › The non-metallic enclosure, houses element terminals and built-in controls; meets NEMA 4X hose-down requirements.
- › Includes automatic reset overtemperature cutout, fan delay relay, controlling contactor, transformer for 24-volt control circuit, terminal block for field wiring, and a separate motor contactor (when required)
- › 304 stainless steel swivel mounting bracket for wall or ceiling mounting—other installation options available



# QWD SERIES

## Washdown Corrosion-Resistant Unit Heater

### Models & Specifications:

ITEM INFORMATION		ELECTRICAL DATA				MOTOR			AIR FLOW			2-STAGE CONTROL	SHIP WT.
CATALOG NO.		VOLTS	PHASE	TOTAL AMPS*	KW	HP	VOLTS	PHASE	RISE**	CFM	THROW		
● QWD02112		120	1	16.7	2.0	—	120	1	9°F	700	—	N/A	60 lbs
● QWD02812		208	1	9.6		—	208	1	9°F	700	—	N/A	60 lbs
● QWD02212		240	1	8.3		—	240	1	9°F	700	—	N/A	60 lbs
● QWD03112		120	1	25	3.0	—	120	1	14°F	700	—	N/A	60 lbs
● QWD03812		208	1	14.4		—	208	1	14°F	700	—	N/A	60 lbs
● QWD03212		240	1	12.5		—	240	1	14°F	700	—	N/A	60 lbs
● QWD03712		277	1	10.8		—	277	1	14°F	700	—	N/A	60 lbs
● QWD03832		208	3	8.3		—	208	1	14°F	700	—	N/A	60 lbs
● QWD03232		240	3	7.2		—	240	1	14°F	700	—	N/A	60 lbs
● QWD03432		480	3	3.6	5.0	—	480	1	14°F	700	—	N/A	60 lbs
● QWD05812		208	1	24		—	208	1	23°F	700	—	N/A	60 lbs
● QWD05212		240	1	20.8		—	240	1	23°F	700	—	N/A	60 lbs
● QWD05712		277	1	18.1		—	277	1	23°F	700	—	N/A	60 lbs
● QWD05412		480	1	10.4		—	480	1	23°F	700	—	N/A	60 lbs
● QWD05832		208	3	13.9		—	208	1	23°F	700	—	N/A	60 lbs
● QWD05232		240	3	12		—	240	1	23°F	700	—	N/A	60 lbs
● QWD05432		480	3	6		—	480	1	23°F	700	—	N/A	60 lbs
● QWD07812		208	1	36.1		—	208	1	34°F	700	—	N/A	60 lbs
● QWD07212		240	1	31.3		7.5	—	240	1	34°F	700	—	N/A
● QWD07712		277	1	27.1	—		277	1	34°F	700	—	N/A	60 lbs
● QWD07412		480	1	15.6	—		480	1	34°F	700	—	N/A	60 lbs
● QWD07832		208	3	20.8	—		208	1	34°F	700	—	N/A	60 lbs
● QWD07232		240	3	18	—		240	1	34°F	700	—	N/A	60 lbs
● QWD07432		480	3	9	—		480	1	34°F	700	—	N/A	60 lbs
● QWD10212		240	1	41.7	10	—	240	1	22°F	1450	—	N/A	60 lbs
● QWD10712		277	1	36.1		—	277	1	22°F	1450	—	N/A	60 lbs
● QWD10412		480	1	20.8		—	480	1	22°F	1450	—	N/A	60 lbs
● QWD10832		208	3	27.8		—	208	1	22°F	1450	—	N/A	60 lbs
● QWD10232		240	3	24.1		—	240	1	22°F	1450	—	N/A	60 lbs
● QWD10432		480	3	12		—	480	1	22°F	1450	—	N/A	60 lbs
● QWD12812		208	1	60.1	12.5	—	208	1	27°F	1450	—	N/A	60 lbs
● QWD12212		240	1	52.1		—	240	1	27°F	1450	—	N/A	60 lbs
● QWD12832		208	3	34.7		—	208	1	27°F	1450	—	N/A	60 lbs
● QWD12232		240	3	30.1		—	240	1	27°F	1450	—	N/A	60 lbs
● QWD12432		480	3	15		—	480	1	27°F	1450	—	N/A	60 lbs
● QWD-234-U11L-0150I		347	1	47		15	¼	347	1	21°F	2400	50"	1A
● QWD-234-U11L-0150D		208	3	44	¼		208	1	21°F	2400	50"	1A	130 lbs
● QWD-234-U11L-0150K		240	3	39	¼		240	1	21°F	2400	50"	1A	130 lbs
● QWD-234-U11L-0150U		480	3	20	¼		480	1	21°F	2400	50"	1A	130 lbs
● QWD-234-U11L-0150Z		600	3	16	¼		600	1	21°F	2400	50"	1A	130 lbs
● QWD-234-U11L-0200U		480	3	26	20		¼	480	1	28°F	2400	50"	1A
● QWD-234-U11L-0200Z		600	3	21		¼	600	1	28°F	2400	50"	1A	130 lbs
● QWD-234-U11A-0250U		480	3	32	25	¼	480	1	35°F	2400	50"	1B	130 lbs
● QWD-234-U11A-0250Z		600	3	26		¼	600	1	35°F	2400	50"	1B	130 lbs
● QWD-234-U11A-0300U		480	3	38	30	¼	480	1	42°F	2400	50"	1B	130 lbs
● QWD-234-U11A-0300Z		600	3	31		¼	600	1	42°F	2400	50"	1B	130 lbs
● QWD-234-U11A-0350U		480	3	44	35	¼	480	1	48°F	2400	50"	1B	130 lbs
● QWD-234-U11A-0350Z		600	3	35		¼	600	1	48°F	2400	50"	1B	130 lbs
● QWD-234-U11A-0390U		480	3	48	38.4	¼	480	1	54°F	2400	50"	1B	130 lbs
● QWD-234-U11A-0390Z		600	3	38		¼	600	1	54°F	2400	50"	1B	130 lbs
● QWD-234-U11A-0470Z		600	3	47	47	¼	600	1	64°F	2400	50"	1B	130 lbs

SKU Legend: ● = Popular Products ● = Extended Offering ■ = Made to Order (Contact your local Marley Sales Representative for typically associated lead times)

Note: Stock heaters ordered with custom options subject to longer delivery. \*Total Amps = Heating element and motor amps. \*\*Approximate air temperature rise.

2-Stage heaters can be field wired as single stage. 1A = Optional 2-stage control, unbalanced (option 'X'). 1B = Optional 2-stage control, balanced (option 'X')

# QWD SERIES

## Washdown Corrosion-Resistant Unit Heater

Scan the QR code  
to access additional  
specs and features



### Factory Built-in Options—2kW-12.5kW Models:

SUFFIX	DESCRIPTION
● T	Thermostat
● L	Pilot Light
● S	Selector Switch
● D	Disconnect Switch
● M	Manual Reset
● P	Epoxy Coating

SKU Legend: ◆ = Popular Products ● = Extended Offering ■ = Made to Order (Contact your local Marley Sales Representative for typically associated lead times)

NOTE: Monel elements are subject to longer lead times. Please contact factory for details. All units other than standard models are non-returnable.

### Factory Built-in Options—15kW-47kW Models:

CATALOG NO.	DESCRIPTION
● B	Delete swivel mounting bracket. Heater installs from the ceiling with field furnished threaded rods
■ C	Epoxy painted stainless steel parts: housing and grilles
● D	Power disconnect switch
■ E	Monel finned tubular elements
■ F8	Fan motor fusing with disconnecting contactor
● L	"Heater on" pilot light
● M	Secondary manual reset overtemperature cutout. Required for U.S. Coast Guard and ABS Approved designs
● S	Three-position selector switch (heater-standby-fan)
● T	1-Stage Built-in thermostat 40° to 100° F
■ T	2-Stage Built-in thermostat 40° to 120° F. <i>Must be installed with 2-Stage Control, X</i>
● V	120 volt control circuit
■ X	2-Stage Control

SKU Legend: ◆ = Popular Products ● = Extended Offering ■ = Made to Order (Contact your local Marley Sales Representative for typically associated lead times)

### Remote Room Thermostat:

CATALOG NO.	SWITCH TYPE	TYPE	RATING	TEMP RANGE	TAMPERPROOF	THERMOMETER	AMPS	PILOT DUTY	COMPATIBILITY
WT11A	Positive snap action switch	SPDT	NEMA 4X rated	40°F-110°F	No	No	25A @ 120-277V	125VA	2kW-12.5kW
WT12A		DPST		40°F-100°F	No	No	25A @ 120-277V	125VA	
1004328	Bulb	SPDT	NEMA 4X	40°-110°F	No	No	25A @ 120-240V 22A @ 277V	125VA	15kW-47kW
1026347		2 SPDT	NEMA 4X	40°-100°F	No	No	25A @ 120-240V 22A @ 277V	125VA	

# QWD SERIES

## Washdown Corrosion-Resistant Unit Heater

Dimensions and Clearances: 2kW-12.5kW Models

Scan the QR code to access additional specs and features

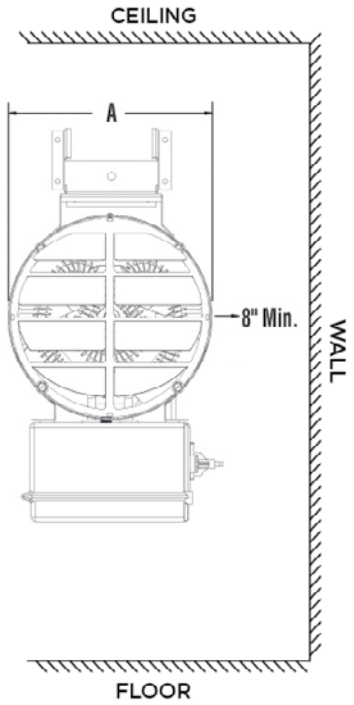
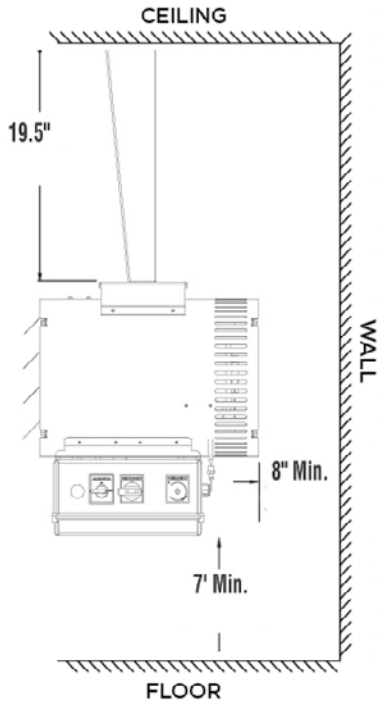
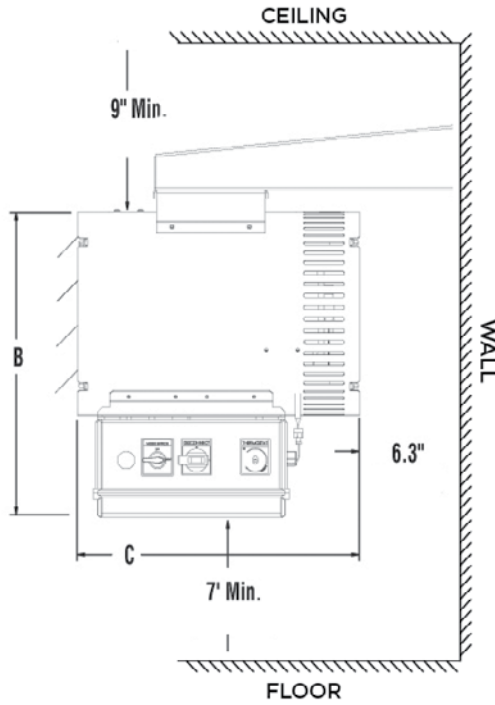

KW	A	B	C	D
2-10	13"	19 1/2"	18"	19 1/2"
12.5	20"	31"	27"	24 1/5"

Dimensions and Clearances: 15kW-47kW Models

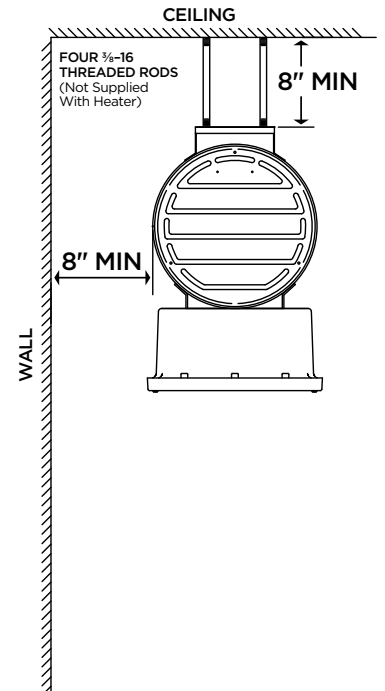
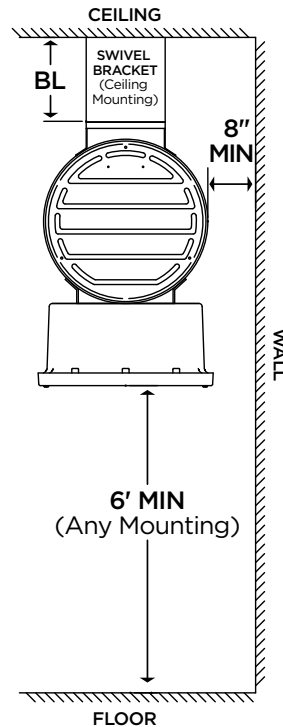
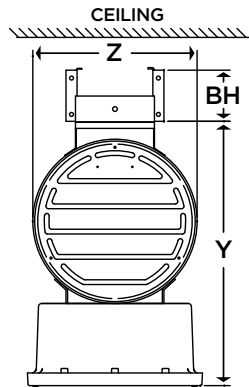
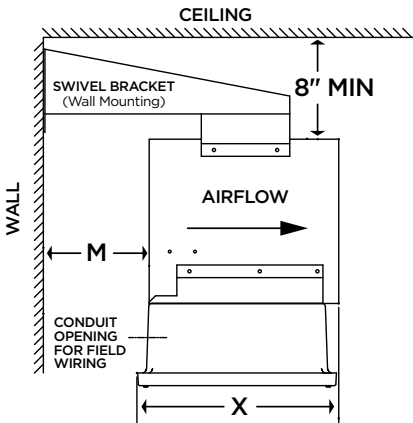

OVERALL			MOUNTING HOLES		
X	Y	Z	BH	BL	M
24 1/2"	26"	20"	7 1/8"	22 1/4"	5"