

WIRE REPLACEMENT INSTRUCTIONS**BERKO SERIES MBB....M ELECTRIC BASEBOARD HEATERS****WARNING**

ONLY QUALIFIED ELECTRICIANS SHOULD ATTEMPT TO MAKE THESE REPAIRS. FAILURE TO FOLLOW THE BELOW PROCEDURE COULD RESULT IN FIRE OR ELECTRIC SHOCK HAZARDS. IN THE EVENT YOU HAVE QUESTIONS REGARDING ANY PORTION OF THIS PROCEDURE, PLEASE CALL OUR TOLL-FREE TECHNICAL SERVICE HOT LINE AT 1-800-642-HEAT (4328).

**CAUTION**

IN THE EVENT THE HEATER HAS BEEN PHYSICALLY DAMAGED OR IS KNOWN TO HAVE BEEN REPEATEDLY SUBJECTED TO MISUSE SUCH AS LOCATED BEHIND A DOOR OR BLOCKED BY FURNITURE, THE HEATER MUST BE REPAIRED OR REPLACED AND RELOCATED OR THE MISUSE CONDITION REMOVED. IF REPAIRING THE UNIT, THE OVER-TEMPERATURE CONTROL AS WELL AS THE CROSSOVER WIRE SHOULD BE REPLACED. THE OVER-TEMPERATURE CONTROL MUST OPERATE PROPERLY TO PREVENT OVERHEATING FROM ABNORMAL CONDITIONS. OTHERWISE PROPERTY DAMAGE OR FIRE COULD RESULT.

INSTRUCTIONS:

1. Disconnect power to the heater at the main switch panel to prevent possible electric shock.

⚠ DANGER

FAILURE TO DISCONNECT POWER TO HEATER COULD RESULT IN SERIOUS INJURY OR DEATH DUE TO ELECTRIC SHOCK.

2. Remove the wiring covers on each end of heater. See Figure 1.

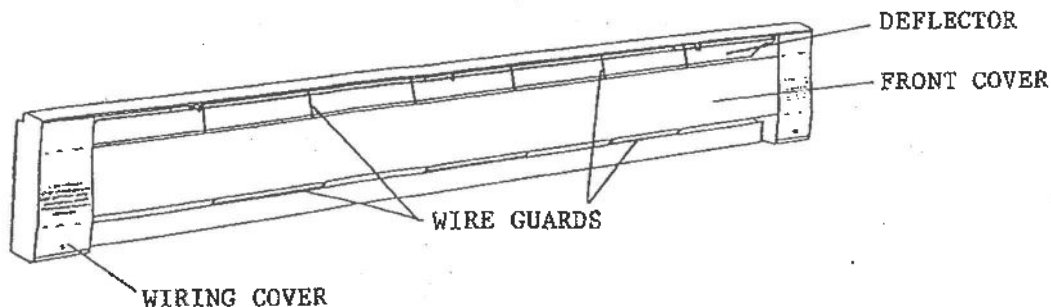
Fig. 1

3. Remove the front cover and all wire guards. Snap deflector loose from each bracket using screw driver pulling downward. See Figure 2.

⚠ CAUTION

USE CARE TO AVOID DAMAGING COPPER (BARE) OVER-TEMPERATURE CONTROL CAPILLARY TUBE ROUTED ALONG THE TOP. DAMAGE TO THIS TUBE COULD RESULT IN PERMANENT DAMAGE TO THE CONTROL WHICH WOULD PREVENT HEATER FROM OPERATING.

Fig. 2

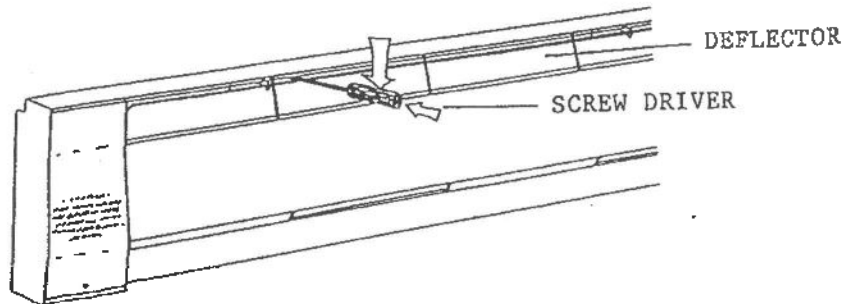

4. Disconnect crossover wire in left wiring compartment.
5. Cut crossover wire in right wiring compartment leaving approximately 6 inches for reconnecting to new wire.
6. Remove and discard old crossover wire.
7. Insert new crossover wire in the exact same location as the old wire. See Figure 3.

⚠ WARNING

MAKE SURE WIRE IS NOT LOOSE AND THAT IT CANNOT FALL BEHIND DEFLECTOR OR BECOME PINCHED BETWEEN DEFLECTOR AND BACK OF HEATER. FAILURE TO PROPERLY LOCATE WIRE COULD ALLOW IT TO BE DAMAGED AND RESULT IN A FIRE OR ELECTRIC SHOCK HAZARD.

Fig. 3

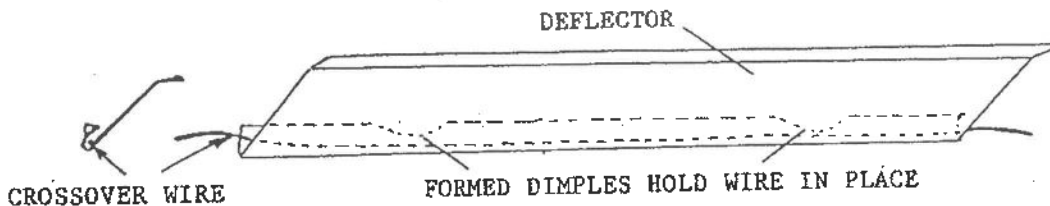

8. Connect new crossover wire in both wiring compartments using appropriate wire nuts making sure all connections are tight. See Wiring Diagram Figure 4.

⚠ WARNING

THE OVER-TEMPERATURE CONTROL MUST REMAIN IN CIRCUIT TO PREVENT A POSSIBLE FIRE IN THE EVENT HEATER IS BLOCKED OR SUBJECTED TO ABNORMAL CONDITIONS.

Fig. 4

HEATERS WITH SUPPLY ENTERING LEFT WIRING COMPARTMENT:

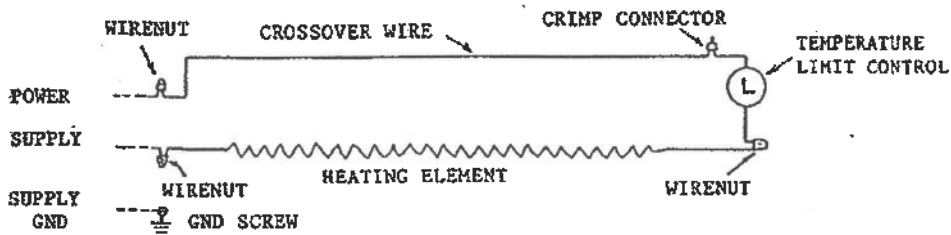

HEATERS WITH SUPPLY ENTERING RIGHT WIRING COMPARTMENT:

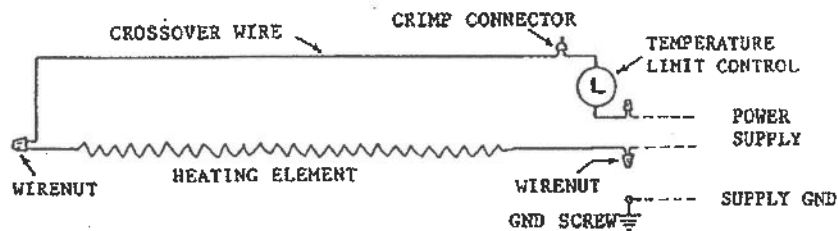

9. Snap deflector back into position making sure wire is in proper position. Be sure deflector snaps into each and every bracket.
10. Replace wire guards, front cover and each wiring compartment cover.
11. Verify the heating element is clean and not damaged and hanging straight without restriction.

⚠ CAUTION

FOR EFFICIENT AND SAFE OPERATION THE ELEMENT MUST BE HANGING STRAIGHT AND BE CLEANED TO ALLOW AIR TO FLOW FREELY THROUGH HEATER. IF HEATING ELEMENT IS TILTED OR IF DUST, LINT, ETC. ARE ALLOWED TO ACCUMULATE AROUND ELEMENT FINS, HEATER WILL OPERATE AT HIGHER TEMPERATURES AND MAY BECOME A RISK OF FIRE.

NOTES:



MARLEY ELECTRIC HEATING
470 Beauty Spot Rd. E.
Bennettsville, SC 29512

5200-2246-001

11/02/94