

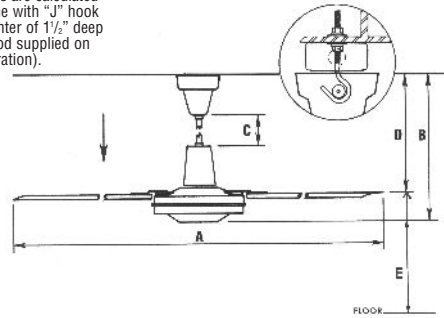

Specialty Ceiling Fans/ Harsh Environment/Spray-Proof Agricultural/Theater

NOTE: All measurements are calculated from ceiling or beam line with "J" hook mounted securely in center of 1 1/2" deep conduit box and downrod supplied on rubber roller (See illustration).



CEILING FAN DIMENSIONS* (mm)

MODELS SUPPLIED WITH 24" DOWNROD					
MODEL SERIES	A	B	C	D	E
48201***	48"	33-1/2"	19"	30-1/2"	10 FT. MIN
48203*** #	48"	35-1/2"	19"	30-1/2"	10 FT. MIN
56003*** #	56"	35-1/2"	19"	30-1/2"	7-10 FT. MIN
56301RDP	56"	33-1/2"	19"	30-1/2"	7-10 FT. MIN
56001**	56"	33-1/2"	19"	30-1/2"	7-10 FT. MIN
60001	60"	34"	19"	30-3/4"	7-10 FT. MIN
MODELS SUPPLIED WITH 12" DOWNROD					
56101	56"	21-3/4"	5-1/2"	18-1/2"	10 FT. MIN
60101	60"	22"	5-3/4"	18-1/2"	10 FT. MIN
56111	56"	21-3/4"	5-1/2"	18-1/2"	10 FT. MIN
60111	60"	22"	5-3/4"	18-1/2"	10 FT. MIN

* Allow for 1/2" variance in "J" hook depth.

** Identical measurements for 220 volt and 277 volt models.

*** Note for models supplied with shorter 8" downrod subtract 13" from measurement scale "C".

These models sold with 3-speed pull chain. All other models sold with wall-mounted adjustable speed controller.

Ceiling Fans to be furnished as specified, Leading Edge. Fans to be U.L. listed Standard 507 with matching U.L. listed solid state controls. All motors to be direct-drive permanent split capacitor type, with permanently sealed ball bearings. All motors to have built in, self-resetting (internal) thermal overload protector TI9700. All fans to have factory installed Secondary Support Cable Assembly connected to motor shaft, with minimum 6 feet galvanized cable 1/8" 7x7 with rated breaking strength of 1700 lbs. and must comply with CSAstd. C22.2 Sept. 1986.

Fan blades to be straight with contoured shaped design for maximum efficiency. Note: Fans installed with blade height less than 10' from floor must have rolled edge blades minimum 3/8" thick in compliance with U.L. 507. Fans to be labeled in accordance with U.L. 507 "Mounted blade height to floor of 7 feet acceptable". Fans used with motor speed controls must be labeled in accordance with U.L. 507 "Suitable for use with solid state motor speed controls".

Factory supplied accessories to include:

- A) Special length downrods
- B) Totally enclosed impact resistant fan guard
- C) Tilted canopy cover
- D) Outdoor location installation kit



PROJECT _____

DATE _____

SHEET _____ OF _____

ENGINEER _____

ARCHITECT _____

CONTRACTOR _____

SUBMITTED BY _____

SCHEDULE

ITEM	QTY.	MARK	MODEL NUMBER	BLADE SWEEP	CFM	AREA COVERAGE	RPM	VOLTS	AMPS	ACCESSORIES	REMARKS

Specialty Ceiling Fans/ Harsh Environment/Spray-Proof Agricultural/Theater



NOTE: All measurements are calculated from ceiling or beam line with "J" hook mounted securely in center of 1 1/2" deep conduit box and downrod supplied on rubber roller (See illustration).

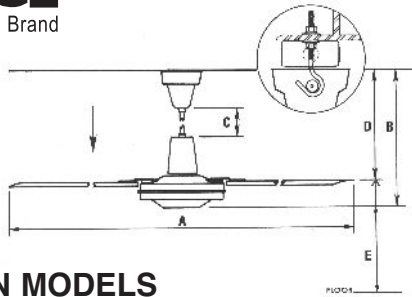

ENERGY EFFICIENCY			
MODEL	AIRFLOW	ELECTRICITY USE	AIRFLOW EFFICIENCY
48201B	7,109 cfm	100.9 watts	70 cfm/watt
48203	7,319 cfm	94.5 watts	77 cfm/watt
56001B	9,826 cfm	117.2 watts	84 cfm/watt
56003	10,135 cfm	113.1 watts	90 cfm/watt
56301RDP	9,502 cfm	114.1 watts	83 cfm/watt
56101	10,257 cfm	119.8 watts	86 cfm/watt
60101	8,806 cfm	129.8 watts	68 cfm/watt
56111	8,836 cfm	109.7 watts	81 cfm/watt
60111	8,607 cfm	131.7 watts	65 cfm/watt

SPECIAL APPLICATION MODELS

MODEL NUMBER	BLADE SWEEP	COLOR	CYCLE	VOLTS	FULL LOAD AMPS	FULL LOAD WATTS	RPM	MAX CFM†	AREA COVERAGE PER FAN††	WEIGHT
48201B	48"	BLACK	50/60	120	.85	86	315	21,000	2025 sq.ft.	22 lbs
48203*	48"	WHT	50/60	120	.85	86	315	21,000	2025 sq.ft.	23 lbs
56001B	56"	BLACK	50/60	120	1.0	110	275	27,500	3800 sq.ft.	24 lbs
56003*	56"	WHT	50/60	120	1.0	110	265	25,500	3025 sq.ft.	26 lbs
56301RDP**	56"	WHT	50/60/60	120	1.0	110	275	27,500	3800 sq.ft.	24 lbs

* Sold with 3-speed pull chain. All other models sold with 12003 (for 120V) or 27708 (for 277V) wall-mounted motor speed controller.

**Reversible, includes toggle switch.

HARSH APPLICATION MODELS

56101	56"	WHT	50/60	120	1.0	110	265	25,500	3025 sq.ft.	24 lbs
60101	60"	WHT	50/60	120	6.4	160	280	41,000	5000 sq.ft.	30 lbs

AGRICULTURAL APPLICATION MODELS

56111	56"	WHT	50/60	120	1.0	110	265	25,500	3025 sq.ft.	24 lbs
60111	60"	WHT	50/60	120	6.4	160	280	41,000	5000 sq.ft.	30 lbs

ACCESSORIES & MISCELLANEOUS ITEMS

MODEL NUMBER	ITEM
28001	• FAN GUARD 62" DIAMETER FOR INDUSTRIAL 56" AND 60" FANS ♦ FAN GUARD 52" DIAMETER FOR COMMERCIAL 36" AND 48" FAN ONLY ♦ TILTED CANOPY COVER DOWNRODS - 8", 12", 24", 30", 36", 48" (FOR LONGER SIZES - CONSULT FACTORY) OUTDOOR LOCATION INSTALLATION KIT
28002	
99994	
99990	
99992	

• Use only with heavy-duty industrial models

♦ Fan Guards ship via UPS

Custom models available. Consult with factory for information and specifications.

OPTIONAL SOLID STATE MOTOR SPEED CONTROLS

MODEL NUMBER	VOLTS	AMPS	CONTROLS	
			48"/120 48201 UNITS	56"/120 56001 56111 56301RDP 56101 UNITS
12003	120	3	2	2
12006	120	6	5	5
12008	120	8	6	6
12012	120	12	10	10
22003	220	3		
22008	220	8		
22012	220	12		
27703	277	3		
27708	277	8		
27712	277	12		

CONTROLS
60"/120
60101
60111
UNITS

NOISELESS MECHANICAL CONTROL

12001N	120	1	1	1	For use with 48" & 56" models only.
12005N	120	5	2	2	

3 YEAR WARRANTY REGISTRATION AGAINST MANUFACTURERS DEFECTS IS INCLUDED WITH EACH FAN.

† Effective amount of air volume moved past a plane 20ft. from fan, industry test. All specifications subject to change and improvement.

†† Area coverage rated for heat destratification at 20' blade mounting height.

