

Open Coil Electric Duct Heaters

Berko® Open Coil Electric Duct Heaters are custom engineered to customer specification and built to order. They are available CSA and UL listed in Slip-in or Flanged configurations with heavy gauge galvanized steel frame and terminal box construction. There are also NEMA 12 and NEMA 4 models available. Units include primary and secondary thermal protection and are designed for use with vertical up or horizontal airflow in either direction. Alternate constructions are available for oven heaters, round duct, bottom insert and rain tight installations. Elements are constructed using only the highest Grade-A 80/20 nickel-chromium resistance wire with stainless steel terminals. Other optional construction features include recessed, dust tight or insulated terminal box, insulated flanges and protective screens.

A wide assortment of built-in control options are available. Exact, not typical, wiring diagrams are provided with each heater.

- ▶ **Custom Engineered**
- ▶ **Heat Output Up to 1000kW**
- ▶ **Grade-A 80/20 Resistance Wire**
- ▶ **Variety of Construction Styles and Options**
- ▶ **Many Control Options**
- ▶ **APPLICATIONS INCLUDE:**
 - Office buildings
 - Institutions
 - Retail stores
 - Primary heat in air handling units
 - Auxiliary heat for heat pumps
 - *and much more*

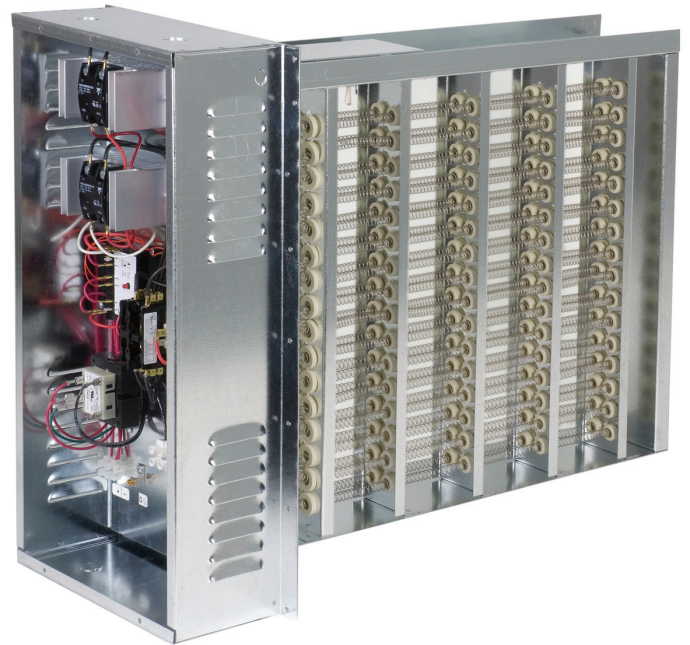

RATING AND SIZES

You specify it—we build it! Heaters described in this bulletin are custom designed at no extra charge to your exact size, wattage, voltage, phase and number of steps. Any duct size from W = 6" and H = 6" minimum to W = 144" and H = 96" maximum, wattages up to 1000 kW can be furnished. Base price depends upon duct size and kW rating; base price is the same for single or three phase and does not change with number of steps. For practical design of heater, minimum recommended kW per step is .5 kW for 208V, 240V single phase; 1.0 kW for 277V or 480V single phase and 2.0 kW for 208V, 240V, 480V or 600V three phase.

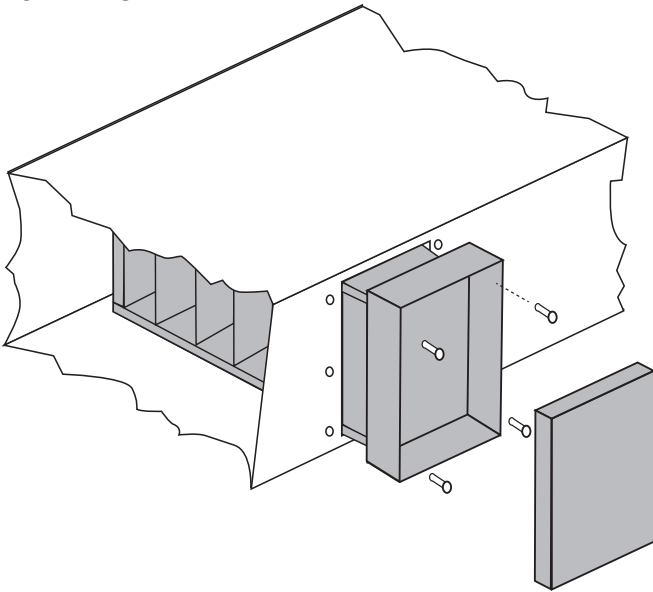
INSTALLATION**SLIP-IN HEATER**

Standard and by far the most widely used because of the ease of installation. When built-in controls are specified in a slip-in heater, they are usually mounted in the left-hand overhang. If right-hand overhang is desired, specify S dimension to be 1"; T dimension as required.

INSTALLATION

- Step 1. Cut hole in side of duct 1/8" larger than heater body.
- Step 2. Insert heater until terminal box covers opening.
- Step 3. Secure heater in place with sheet metal screws.

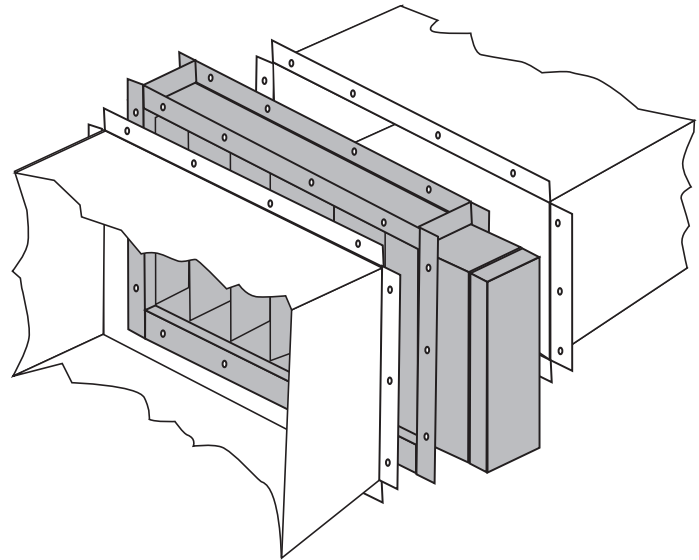
**FLANGED HEATER (Optional)**

Consists of a slip-in heater mounted in a flanged duct section. The slip-in portion slides out without removing flanges from duct. When built-in controls are specified in a flanged heater, they are mounted in the terminal box of the slip-in portion; the frame containing the elements stays the same. The flanged duct section is increased in depth to accommodate the larger terminal box.

INSTALLATION

- Step 1. Provide flanges on ends of duct matching heater flanges.
- Step 2. Secure heater flanges to duct flanges with sheet metal screws, so that mounting screws do not enter terminal box.

SAMPLE CATALOG NUMBER

FC 035 08 1 03 1 N N Y 024500 18625

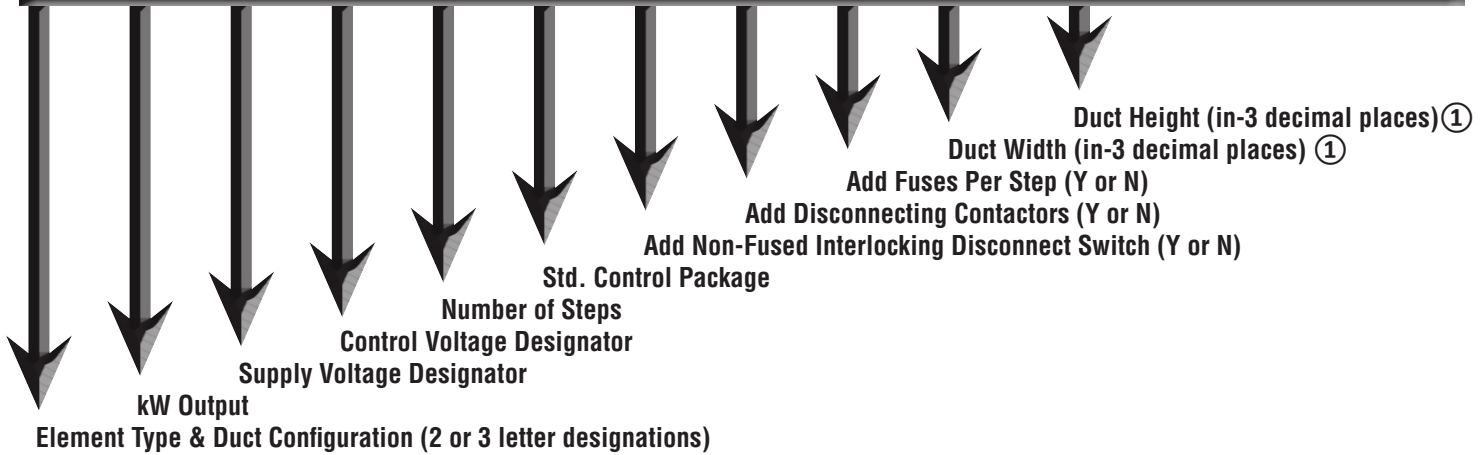

① - On standard heaters width (W) must not exceed 144" and height must not exceed 96". Consult factory for larger heaters.

Open Coil, 24-1/2"W X 18-5/8"H duct, 480V, 3Ø, 3-wire supply voltage, 24v, 1Ø control voltage, 35 kW, Slip-In duct configuration, with three steps and fuses for each step.

OPEN COIL DESIGNATION

FC	Flanged Open Coil
SC	Slip-In Open Coil
RFC	Round Duct Open Coil

VOLTAGE DESIGNATION

(CONTROL VOLTAGE TO THE UNIT)

1	24V, 1Ø
---	---------

VOLTAGE DESIGNATION

(SUPPLY VOLTAGE TO THE UNIT)

1	120V, 1Ø
2	208V, 1Ø
3	208V, 3Ø 3-WIRE
4	240V, 1Ø
5	240V, 1Ø 3-WIRE
6	277V, 1Ø
7	347V, 1Ø
8	380V, 1Ø
9	380V, 3Ø 3-WIRE
10	400V, 1Ø
11	400V, 3Ø 3-WIRE
12	416V, 1Ø
13	416V, 3Ø 3-WIRE
14	460V, 1Ø
15	460V, 3Ø 3-WIRE
16	480V, 1Ø
17	480V, 3Ø 3-WIRE
18	480V, 3Ø 4-WIRE
19	575V, 1Ø
20	575V, 3Ø 3-WIRE
21	600V, 1Ø

Minimum and maximum sizes available

STANDARD CONTROL PACKAGES (SEE CONTROLS BROCHURE FOR PACKAGE DETAILS)

- 1 Contains a disconnecting magnetic operating contactor, fuses (heaters > 48 amps), and line-voltage to 24V control transformer.
- 2 Contains a disconnecting magnetic operating contactor, fuses (heaters > 48 amps), a line-voltage to 24V control transformer with primary fuses, and electronic step control.
- 3 Contains a disconnecting magnetic safety contactor, a disconnecting magnetic operating contactor per step, fuses (heaters > 48 amps), SCR control, SCR Vernier System, and line-voltage to 24V control transformer.
- 4 Contains a disconnecting magnetic safety contactor, fuses (heaters > 48 amps), SCR control and line-voltage to 24V control transformer.

TECHNICAL SPECIFICATION

General: Electric duct heaters shall be as provided by Berko, A Marley Engineered Products Brand. Voltage, size, KW, steps and control voltage shall be as scheduled. Three phase heaters shall have balanced phases.

1. Heaters shall be CSA and UL Listed for zero clearance and shall meet all NEC requirements, unless otherwise specified.
2. Type: Heaters shall be of the following configuration:
For Duct Mounting All Slip-in or Flanged
For Air Handling Unit Coils All Slip-in or Flanged
Multi zone Hot Deck Coils Slip-in Type
3. Open coil heating elements shall be 80% nickel and 20% chromium; steps shall be arranged to prevent stratification when operating at less than full capacity. Elements for draw-through air handling units shall be de-rated to 35 watts per square inch; blow-through air handling coils and variable volume reheat coils shall be de-rated to 25 watts per square inch.
4. Element terminals shall be stainless steel; insulators and bracket bushings shall be nonporous ceramic and securely positioned. Terminals shall be machine crimped to elements.
5. Frame shall be constructed of heavy gauge galvanized steel with galvanized steel brackets, stiffening ribs and gussets spot welded to the frame. Stainless and Aluminized steel frames are available.
6. Terminal box shall be spot welded construction with solid, hinged cover, totally enclosed, without louvers or grilles per the CSA and UL Standard, unless otherwise specified.
7. Recessed terminal box to be provided when coils are installed in ducts with internal insulation or obstruction greater than 1".
8. Direction of airflow: heaters shall be interchangeable for horizontal left or right or vertical up airflow except when position sensitive mercury contactors or SCRs are built-in. In these cases, airflow direction shall be as scheduled.
9. Safety devices: a disc-type automatic reset thermal cutout shall be furnished for primary over temperature protection. For secondary protection, a sufficient number of replaceable thermal cutouts in the power lines shall de-energize elements if the primary cutout fails. All safety devices shall be serviceable through the terminal box without removing the heater from the duct.
10. Wiring diagrams: a unique wiring diagram shall be furnished for each heater. Diagram shall include recommended supply wire gauges per NEC and fuse sizes.
11. Built-in components shall include safety interlocking disconnect switch, disconnecting break magnetic contactors, transformer with primary fusing per CSA and UL, pressure-type airflow switch set at .05" WC, supplementary circuit fuses per NEC (one set of fuses per 48 amp circuit), and separate load and control terminal blocks to accept conductors as shown on the electrical plan.

12. Special features: the following special features are available:

SPECIAL CONSTRUCTION

- Insulated Terminal Box
- Dust tight Terminal Box
- Weather Resistant Terminal Box (non-removable flange)
- Recessed Terminal Box
- Bottom Insert - open coil only
- Round-duct Construction
- Stainless Steel Frame
- Aluminized Steel Frame
- Hinged Terminal Box Cover
- High Pressure Construction
- Protective Screens
 - A. Inlet Side Only
 - B. Outlet Side Only
 - C. Both Sides

OVER-CURRENT PROTECTION

- Automatic Circuit Breakers (in lieu of fuses)
- Fuses Per Step (in lieu of one per 48 amperes)
- Main Supply Over-current Protection (heaters 48 amperes or less)

OVER-TEMPERATURE PROTECTION

- Manual Reset Thermal Cutout in control circuit in series with automatic
- Manual Reset Thermal Cutout in power lines (in lieu of secondary cutouts)
- Manual Reset Thermal Cutout operating back-up contactors
- Automatic Reset Thermal Cutout

SWITCHING DEVICES AND CONTROLS

- Magnetic Contactors, De-energizing (in lieu of disconnecting)
- SCRs (solid state modulating control)
- Toggle Switch(es)
 - A. One Per Step
 - B. Interrupts Control Voltage
 - C. NEMA 12
- Door Interlock Switch (to break control circuit)
- Step Controller(s) (specify input)
 - A. Electronic Modulating
- Time Delay Relay
- PE Switch(es) (for pneumatic control; specify close or open on pressure rise)
- Transducer (pneumatic to 135 Ohm)
- Pilot Light(s)
 - A. One Per Step (x # of steps)
 - B. Control Voltage ON
 - C. Power ON (Line Volts)
 - D. Normal Operation (Automatic Reset Circuit is Closed)
 - E. Airflow Switch Open
 - F. Manual Reset Thermal Cutout ON
 - G. Push-To-Test Type (Not CSA and UL except with 16E)
 - H. Over-temperature (Automatic Reset Cutout Circuit is Open)
 - I. Nema - 12 (non-CSA and UL) or Nema - 4 (non-CSA and UL)
 - J. Heater ON

13. Manufacturer to provide two year limited warranty.