

PROJECT _____	ENGINEER _____	SUBMITTED BY _____
DATE _____	ARCHITECT _____	_____
SHEET _____ OF _____	CONTRACTOR _____	_____

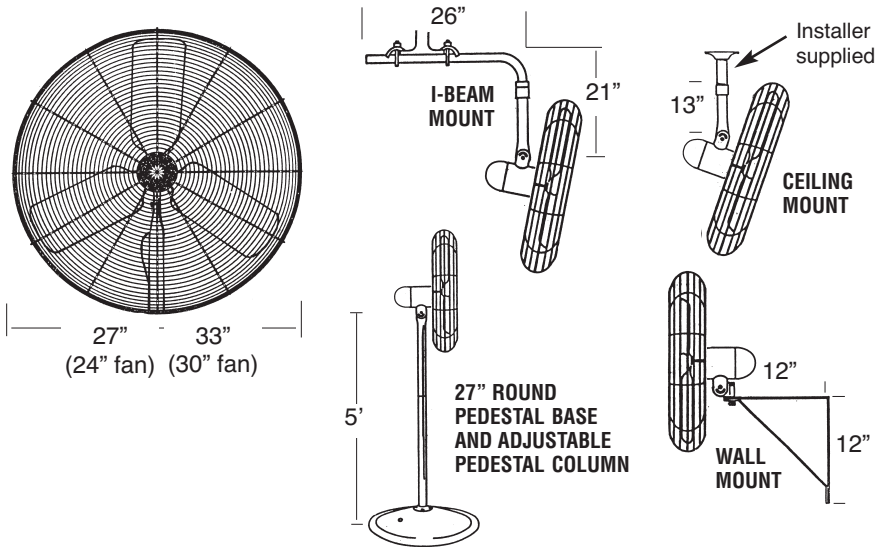

SPECIFICATIONS

- 24" and 30" diameter.
- 2 Speed, 1/3 HP, single phase, 120 volt, totally enclosed, permanently lubricated ball bearings, built-in thermal overload protection, permanent split capacitor motor with 5' long air actuated pendant switch.
- Precision balanced aluminum blades.
- Zinc plated guards meeting OSHA safety standards.
- Rear dome design allows for servicing or replacement of switch or capacitor.
- Meets UL 507 spray test requirements.
- Fan motor and mounts are coated with FDA approved epoxy paint and are USDA approved for incidental food contact.

OPTIONAL MOUNTS

- Wall*
- Ceiling*
- I-Beam*
- 27" Round Base

*All wall, ceiling and I-beam mounts come with Secondary Support Cable.

ITEM	QTY	MARK	MODEL NUMBER	BLADE SIZE	FAN STYLE	CFM		RPM		MOTOR H.P.	MAX AMPS	REMARKS
						HI	LOW	HI	LOW			

SPECIALITY WASH DOWN SERIES AIR CIRCULATOR SUBMITTAL SHEET