

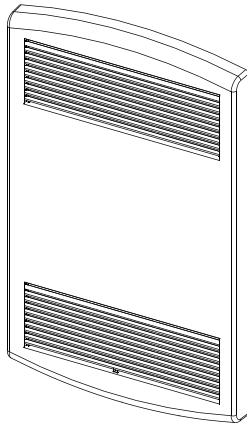

SUBMITTAL SHEET
ECP SERIES
 EURO STYLE NON-FAN
 FORCED WALL HEATERS

ECP SERIES - EURO STYLE WALL HEATERS, NON-FAN FORCED



CAPACITIES
750, 1000, 1125 or 1500 WATTS 208 or 240V 1Ø ONLY



JOB NAME: _____

LOCATION: _____

ARCHITECT: _____

ENGINEER: _____

CONTRACTOR: _____

SUBMITTED BY: _____

DATE: _____

ITEM	QTY.	CATALOG NUMBER	TAG	WATTS	VOLTS	PHASE Ø	AMPS

ACCESSORIES
AND
CONTROLS

ITEM	QTY.	CAT. NO.	TAG	DESCRIPTION



A Marley Engineered Products Brand

470 Beauty Spot Rd. E, Bennettsville, SC 29512

ARCHITECT’S & ENGINEER’S SPECIFICATIONS*

Furnish and install, where indicated on plans, electric non-fan forced wall heater suitable for small area heating as manufactured by QMark, A Marley Engineered Products Brand, Bennettsville, SC. Heaters shall be cCSAus Listed. The heater shall be designed for wall mounting, recess or surface.

ENCLOSURE: The heater shall be fabricated of 20-gauge cold-rolled steel, completely welded, then painted with a corrosive resistant polyester powder paint coating. The heavy duty metal grille and grille frame shall be polyester powder paint coated.

HEATING ELEMENT: The heating element shall be of non-glowing design consisting of special resistance wire enclosed in a steel sheath to which steel fins are mechanically crimped.

WIRING COMPARTMENT: The heater housing shall contain an enclosed wiring compartment to isolate all live electrical parts from the remainder of the heater. An integral disconnect plug will allow the heater to be removed from the housing without disturbing the wiring compartment and to permit easy installation.

GENERAL: The heater shall be rated to operate at 208 or 240 VAC. A thermal cutout shall shut off the heater in the event of overheating.

* MEP reserves the right to change specifications without prior notice.

** Limitations: Do not install in areas where water may enter heater unit. Do not locate where air flow may be obstructed (under drapes, behind doors, etc.). Do not install in ceiling or floors.

DIMENSIONS

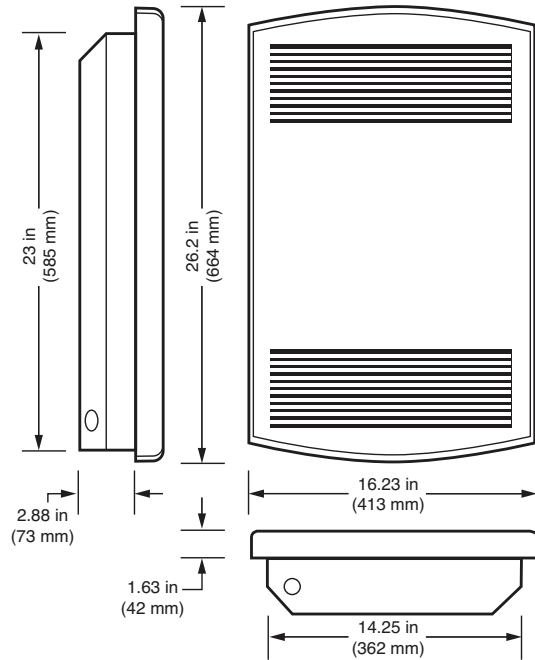

SELECTION CHART

CATALOG NUMBER	VOLTS	WATTS	AMPS	PHASE	BTU/HR
ECP1024	240/208	1000/750	4.2/3.6	1	3412/2560
ECP1524	240/208	1500/1125	6.3/5.4	1	5123/2560

1500 WATT MODELS ONLY
ECP1524

1000 WATT MODELS ONLY
ECP1024

